

FATTY ACID METABOLISM IN CAENORHABDITIS ELEGANS:
CHARACTERIZATION OF THE DELTA-9 FATTY ACID
DESATURASES AND IDENTIFICATION
OF A KEY REGULATOR, NHR-80

By

TRISHA JANE BROCK

A dissertation submitted in partial fulfillment of
The requirements for the degree of

DOCTOR OF PHILOSOPHY IN GENETICS AND CELL BIOLOGY

WASHINGTON STATE UNIVERSITY
School of Molecular Biosciences

DECEMBER 2005

To the Faculty of Washington State University:

The members of the Committee appointed to examine the dissertation of TRISHA JANE BROCK find it satisfactory and recommend that it be accepted.

Chair

ACKNOWLEDGEMENTS

Thank you to Dr. John Browse and Dr. Jennifer Watts for providing invaluable support and guidance throughout my graduate career. Thank you also to the rest of the Browse lab past and present for their support and technical guidance, with special appreciation for my classmates Becky Olsen and Bryan Thines. In addition, I am grateful to the members of my committee Dr. Nancy Magnuson, Dr. Michael Griswold, Dr. Patricia Hunt, and Dr. John Rogers who provided immense guidance. Dr. Shohei Mitani (Tokyo Women's Medical University, Japan) provided the *nhr-80(tm1011)*, *fat-5(tm420)*, *fat-6(tm331)*, and *fat-7(tm326)* mutants. Dr. Edwin Cuppen (Hubrecht Institute, The Netherlands) provided the *fat-7(wa36 and wa37)* mutants. Dr. Marc Van Gilst (University of Washington) provided the primer sequences for the metabolism genes used in RT-QPCR and Dr. Andy Fire (Stanford University, California) provided vectors. Funding was provided by the NIH Biotechnology Training Program at WSU and by NIH R01 GM62521.

FATTY ACID METABOLISM IN CAENORHABDITIS ELEGANS:
CHARACTERIZATION OF THE DELTA-9 FATTY ACID
DESATURASES AND IDENTIFICATION
OF A KEY REGULATOR, NHR-80

Abstract

by Trisha Jane Brock, Ph.D.
Washington State University
December 2005

Chair: John Browse

Abstract

The $\Delta 9$ fatty acid desaturases are key enzymes in fatty acid metabolism that introduce a double bond in a saturated fatty acid (SFA) chain to generate a monounsaturated fatty acid (MUFA). The nematode *C. elegans* has a family of three $\Delta 9$ desaturases called FAT-5, FAT-6, and FAT-7. Production of MUFAs by these desaturases is the first step of the desaturation pathway and these MUFAs are incorporated into lipids such as phospholipids and triglycerides where they play essential roles in membrane fluidity and energy storage. Because of the importance of maintaining the proper ratio of SFA to MUFA in a cell the $\Delta 9$ desaturases have extensive transcriptional regulation. We have identified a novel nuclear hormone receptor, NHR-80, in *C. elegans* that regulates $\Delta 9$ desaturase gene expression and fatty acid composition. We have also examined the $\Delta 9$ desaturase single mutants and found that they are functionally redundant; however, analysis of the *fat-5;fat-6;fat-7* triple mutant and *nhr-*

80;fat-6 double mutant reveals that $\Delta 9$ desaturation and the MUFAs produced are essential for survival.

To further examine the effect of alterations in fatty acid composition we have generated double mutant combinations of *fat-5;fat-6*, *fat-5;fat-7*, and *fat-6;fat-7*. While *fat-5;fat-6* and *fat-5;fat-7* double mutants are indistinguishable from wild-type under standard conditions the *fat-5;fat-6* double mutants do show reduced survival under conditions of stress, such as low temperature and starvation. Analysis of fatty acid composition in these stress conditions reveals a role for *fat-5* and *fat-6* in maintaining proper fatty acid composition for surviving stress conditions. The *fat-6;fat-7* double mutant has a striking phenotype under standard growth conditions. These double mutants have slower growth, reduced fertility and reduced fat storage phenotypes that can be biochemically complemented with dietary fatty acid supplementation. These double mutants are severely altered in their fatty acid composition and produce some unusual polyunsaturated fatty acids (PUFAs). Examination of gene expression in these double mutants has linked the decreased fat stores to an increase in β -oxidation. The *fat-6;fat-7* double mutants reveal the essential roles for *fat-6* and *fat-7* in maintaining proper fatty acid composition and as crucial enzymes in energy metabolism pathways.

TABLE OF CONTENTS

	Page
ACKNOWLEDGEMENTS	iii
ABSTRACT.....	iv
LIST OF TABLES	viii
LIST OF FIGURES	ix
CHAPTER ONE	
GENERAL INTRODUCTION	1
REFERENCES	8
CHAPTER TWO	
1. ABSTRACT	10
2. INTRODUCTION	11
3. RESULTS AND DISCUSSION	16
4. MATERIALS AND METHODS	24
5. REFERENCES	31
CHAPTER THREE	
1. ABSTRACT	42
2. INTRODUCTION	43
3. RESULTS AND DISCUSSION	46
4. MATERIALS AND METHODS	52
5. REFERENCES	55

CHAPTER FOUR

1. ABSTRACT	61
2. INTRODUCTION	62
3. RESULTS AND DISCUSSION	67
4. MATERIALS AND METHODS	76
5. REFERENCES	80

APPENDIX

A. CHARACTERIZATION OF HIGH 18:0 MUTANTS.....	93
B. THE FAT-7(TM326) ALLELE	106
C. FAT-7 RNA INHIBITION	113

LIST OF TABLES

CHAPTER FOUR

1. Fatty acid composition of *C. elegans* mutants with low PUFAs83

LIST OF FIGURES

CHAPTER ONE

1. The pathway for fatty acid desaturation and elongation in *C. elegans*9

CHAPTER TWO

1. Diagram of *nhr-80*, *fat-5*, *fat-6*, and *fat-7* gene structure35
2. Fatty acid composition of *nhr-80*.....36
3. Expression of the $\Delta 9$ desaturases in *nhr-80*.....37
4. Fatty acid composition of the $\Delta 9$ desaturase mutants38
5. Aging of adult mutant populations39
6. Expression of the $\Delta 9$ desaturase genes in the $\Delta 9$ desaturase mutants.....40
7. Effects of *nhr-80(RNAi)* in the $\Delta 9$ desaturase mutant background.....41

CHAPTER THREE

1. The *fat-5;fat-6* double mutants under standard growth conditions.....57
2. Fatty acid composition of the $\Delta 9$ desaturase double mutants58
3. Cold sensitivity in the *fat-5;fat-6* double mutants59
4. Starvation sensitivity in the *fat-5;fat-6* double mutants.....60

CHAPTER FOUR

1. Fatty acid composition of *fat-6;fat-7* double mutants.....84
2. Desaturation pathways in the *fat-6;fat-7* double mutants85
3. Aging of adult wild-type, and *fat-6;fat-7* double mutant populations at 20°C86
4. Growth rates in *fat-6;fat-7* double mutants.....87

5. Fertility in <i>fat-6;fat-7</i> double mutants.....	88
6. Fat storage by Nile red staining in <i>fat-6;fat-7</i> double mutants	89
7. Fatty acid composition of lipid classes in wild-type and <i>fat-6;fat-7</i>	90
8. Upregulation of fatty acid β -oxidation genes in <i>fat-6;fat-7</i> double mutants	91

APPENDIX ONE

1. % 18:0 in the high 18:0 mutants grown on <i>nhr-80(RNAi)</i>	101
2. Aging of adult <i>wa3</i> mutants.....	102
3. Effects of temperature on <i>wa3</i>	103
4. Expression of the $\Delta 9$ desaturases in the high 18:0 mutants.....	104
5. Fatty acid composition of the <i>wa3</i> mutants	105

APPENDIX TWO

1. Model of <i>fat-7(tm326)</i> showing the deletion and insertion	111
2. PCR results from <i>fat-7(tm326)</i>	112

APPENDIX THREE

1. Knock-down of $\Delta 9$ desaturase gene expression by <i>fat-7(RNAi)</i>	119
2. Sequence alignment of <i>fat-5</i> , <i>fat-6</i> , and <i>fat-7</i>	120
3. Fatty acid composition of <i>fat-7(RNAi)</i> worms.....	122
4. Fertility of <i>fat-7(RNAi)</i> worms.....	123

CHAPTER ONE

GENERAL INTRODUCTION

Fatty acids are essential molecules with many roles within a cell. They are critical for membrane function, energy storage, and cell signaling. The general structure of a fatty acid is a long hydrocarbon chain with carbon molecules connected by single or double bonds. The length of the carbon chain, the double bonds, and the position of those double bonds all determine the physical properties of fatty acids and that determines their unique functions.

Membranes are essential to separate cells from their surroundings. In eukaryotic cells, membranes also surround the organelles allowing for organization of biological processes through compartmentalization. The fatty acid component of membranes is essential for their function. Membranes are comprised of lipids, proteins, and carbohydrates. The most abundant lipids are generally phospholipids of which fatty acids are a constitutive part. Fatty acids give phospholipids a non-polar tail, which is vital for the selective permeability provided by membranes. Hydrophobic molecules, such as oxygen, and very small polar molecules, like water, can pass through the membrane unaided. However, larger polar molecules like glucose, and ions such as H^+ , are not able to pass through the membrane and must rely on transport proteins to move in and out of a cell. This allows for the generation of gradients such as the proton-motive force that is used to generate ATP.

Triglycerides (TAGs), the molecules of fat storage, are also composed of fatty acids. TAGs function as energy reserves in plants and animals allowing them to store excess energy for later use. For instance, breakdown of one 16-carbon fatty acid with no

double bonds provides 106 molecules of ATP compared with the 36 molecules of ATP generated by the breakdown of one molecule of glucose. Each TAG molecule contains three fatty acids esterified to a glycerol backbone.

Cells contain a variety of fatty acid species to carry out these roles in membrane fluidity and energy storage. Fatty acid synthesis generates a 16-carbon fatty acid with no double bonds. This saturated fatty acid (SFA) is then acted upon by desaturases, which add double bonds, and elongases, which add carbons, to generate all the different fatty acids that function in a cell. An example of this can be seen in *C. elegans*, which produce about 10 major fatty acids including a 20-carbon fatty acid with 5 double bonds (eicosapentaenoic acid or 20:5 ω 3) (Hutzell and Krusberg, 1982). (The fatty acid nomenclature used throughout this dissertation is X:YnZ where X represents the number of carbons and Y the number of double bonds. Z refers to the position of those double bonds with n as Δ or ω indicating position relative to the carboxyl end or the methyl end of the fatty acid, respectively.) In the substrate preferences for the desaturases and elongases that modify fatty acids there is specificity for carbon length, double bond number, and double bond position in the fatty acid. The desaturases also are specific in adding a double bond at a defined position within the fatty acid. The enzymes that modify fatty acids are highly regulated both transcriptionally and post-translationally (Ntambi and Miyazaki, 2004), which gives evidence to the important function of these fatty acid species; however, the reasons for the variety of fatty acids produced by higher eukaryotes is not clear.

C. elegans is a good animal model for studying fatty acid metabolism. These nematodes are small, fast growing, and easy to maintain in the lab, characteristics valued

in a model organism. When grown on a bacterial lawn of *E. coli* one adult hermaphrodite can produce over 250 progeny, which will themselves become adults within three days of hatching from their eggs. In addition there are a great deal of tools and resources developed by the community that uses this model. The genome sequence was announced in 1998 (Consortium, 1998) and is available to the public. Many important biological processes have been conserved throughout animal evolution. Thus we can gain insight to human disease by understanding the process in a simpler system, such as *C. elegans*. An example of a conserved pathway is the insulin signaling pathway which regulates energy homeostasis in worms, flies, and humans through many homologous proteins (Porte et al., 2005).

Another valuable tool available for the study of *C. elegans* is the library of RNAi clones that can inhibit the function of 86% of the predicted genes of the worm. In *C. elegans*, RNAi can be induced by ingestion of dsRNA. Researchers have created a library of almost 17,000 bacterial strains each containing an ORF of *C. elegans* cloned into a vector that produces dsRNA (Kamath et al., 2003). When the worm eats the bacteria it also eats the dsRNA and the inhibition of that specific endogenous gene expression spreads throughout the worm. This is a powerful and rapid method for exploring gene function and has been used in many ways including a screen for genes affecting fat storage. Animals grown on the RNAi library were screened for changes in fat storage measured by Nile red, a lipophilic dye that stains fat droplets in the intestine. They identified 112 gene inactivations that caused an increase in fat storage and 305 gene inactivations that caused a decrease (Ashrafi et al., 2003). Many of the genes identified

have mammalian homologues, which may prove useful in our understanding and treatment of human obesity.

Our lab began its work on *C. elegans* fatty acid metabolism by searching the *C. elegans* genome sequence for homologues of *Arabidopsis* desaturases. Desaturases have three highly conserved histidine-rich domains involved in coordinating iron at the active site (Stukey et al., 1990). Using sequence searching and expression in heterologous systems they identified *fat-1* an ω 3 desaturase (Spychalla et al., 1997), *fat-2* a Δ 12 desaturase (Peyou-Ndi et al., 2000), *fat-4* a Δ 5 desaturase (Watts and Browse, 1999), and the Δ 9 desaturases *fat-5*, *fat-6*, and *fat-7*. Along with *fat-3* a Δ 6 desaturase (Napier et al., 1998), these are the desaturases responsible for creating the complex fatty acid profile of *C. elegans*. These animals produce about 10 major fatty acids including SFAs like 16:0 and 18:0, monounsaturated fatty acids (MUFAs) like 18:1 Δ 9 and 18:1 Δ 11, and polyunsaturated fatty acids (PUFAs) like 18:2 ω 6 and 20:5 ω 3 (Hutzell and Krusberg, 1982). The fatty acid composition of worm populations is easy to measure by gas chromatography and this was exploited in a screen to identify *C. elegans* with altered fatty acid compositions (Watts and Browse, 2002). They found many mutations that caused an alteration in fatty acid composition including mutations in the desaturase genes *fat-1*, *fat-2*, *fat-3*, and *fat-4*.

The results from the screen along with the data from heterologous expression allowed for the determination of the pathway of PUFA synthesis in *C. elegans* (Figure 1). The SFA 16:0 is produced from fatty acid synthase or obtained from the *E. coli* diet. FAT-5 acts on this SFA to produce the MUFA 16:1 Δ 9, which is elongated to 18:1 Δ 11. The SFA 16:0 can also be elongated to 18:0, which is desaturated to 18:1 Δ 9 by FAT-6 or

FAT-7. 18:1 Δ 11 and 18:1 Δ 9 are both 18-carbon MUFAs but they have different roles within the worm. 18:1 Δ 9 is the substrate for the FAT-2 Δ 12 desaturation to 18:2 ω 6. FAT-2 does not act on 18:1 Δ 11. The 18:2 ω 6 produced by FAT-2 is converted to an 18:3 by FAT-1 or FAT-3. The Δ 6 desaturation provided by FAT-3 is required for elongation of 18-carbon PUFAs to 20-carbon PUFAs by ELO-1 and ELO-2. FAT-1 and FAT-4 modify the 20-carbon PUFAs to generate 20:5 ω 3.

No mutations in the three Δ 9 desaturases identified by sequence identity and expression in yeast were found in the screen for mutants with altered fatty acid profiles. These mutants would not have been discovered if the knockouts had no change in fatty acid composition due to redundancy or if the knockouts were lethal. Δ 9 desaturation is a central part of fatty acid metabolism. As illustrated in the pathway described in Figure 1, they are the first step in desaturation and are necessary for generation of MUFAs from SFAs. It is not immediately apparent why there are three Δ 9 desaturases isozymes in *C. elegans* as all of the other desaturases in *C. elegans* have only one isoform. The goal of this project was to identify the different roles the Δ 9 desaturases play in the worm and to use the Δ 9 desaturase mutants to explore the roles of SFAs and MUFAs on cell biology and animal physiology.

The second chapter describes our characterization of the Δ 9 desaturases. We examined the single mutants and found that they were almost indistinguishable from wild-type. They do have slight changes in fatty acid composition, differences that are amplified in *fat-5* and *fat-6* mutants by growth in axenic culture medium. The Δ 9 desaturases are all expressed in the intestine, which is the major site of fatty acid metabolism in *C. elegans*. Though these genes show overlap in function we know that

the $\Delta 9$ desaturases are essential as worms that lack all $\Delta 9$ desaturase activity, the *fat-5;fat-6;fat-7* triple mutants, are not able to survive. We also have identified a nuclear hormone receptor, NHR-80, that is involved in maintaining proper fatty acid composition and *fat-7* expression. Without this transcription factor worms have an increase in the SFA 18:0 and *fat-7* expression is virtually eliminated. From this work we see that there is redundancy in the $\Delta 9$ desaturases but their regulation and expression is required for normal growth and development.

In the third chapter we have revealed the phenotypes of the *fat-5;fat-6* double mutants. These double mutants are increased in SFAs and decreased in MUFAs, but this change in fatty acid composition appears to have no effect on normal growth and development under standard growth conditions. However, under stress conditions these double mutants display a reduced survival. At low temperatures wild-type animals have a decrease in SFAs and an increase in MUFAs. The *fat-5;fat-6* double mutants do not show this shift in fatty acid composition and are not able as wild-type to survive low temperatures. Wild-type animals can survive starvation for about six days but the *fat-5;fat-6* double mutants can only survive for about two days. The wild-type animals show little change in their fatty acid composition but the *fat-5;fat-6* double mutants are composed of much more SFAs and less MUFAs when they are starved. Thus we see a requirement for *fat-5* or *fat-6* during stress conditions.

Chapter Four explains the energy metabolism phenotypes of the *fat-6;fat-7* double mutant. These double mutants lack the ability to generate 18:1 $\Delta 9$ and thus produce none of the normal PUFAs synthesized using this substrate (Figure 1). The *fat-6;fat-7* double mutants have slow growth and reduced fertility that can be biochemically complemented

by dietary fatty acid supplementation. In addition to the growth phenotypes, the *fat-6;fat-7* double mutants are reduced in fat storage, as measure by Nile red staining and TAG analysis. This is likely due to an increase in fatty acid β -oxidation. This is the first description of a viable low fat mutant in *C. elegans* indicating the requirement of *fat-6* or *fat-7* for normal energy metabolism.

References

- Ashrafi, K., Chang, F. Y., Watts, J. L., Fraser, A. G., Kamath, R. S., Ahringer, J., and Ruvkun, G. (2003). Genome-wide RNAi analysis of *Caenorhabditis elegans* fat regulatory genes. *Nature* *421*, 268-272.
- Consortium, T. C. e. S. (1998). Genome sequence of the nematode *C. elegans*: a platform for investigating biology. *Science* *282*, 2012-2018.
- Hutzell, P. A., and Krusberg, L. R. (1982). Fatty Acid Compositions of *Caenorhabditis elegans* and *C. briggsae*. *Comparative Biochemistry and Physiology* *73B*, 517-520.
- Kamath, R. S., Fraser, A. G., Dong, Y., Poulin, G., Durbin, R., Gotta, M., Kanapin, A., Le Bot, N., Moreno, S., Sohrmann, M., *et al.* (2003). Systematic functional analysis of the *Caenorhabditis elegans* genome using RNAi. *Nature* *421*, 231-237.
- Napier, J. A., Hey, S. J., Lacey, D. J., and Shewry, P. R. (1998). Identification of a *Caenorhabditis elegans* Delta6-fatty-acid-desaturase by heterologous expression in *Saccharomyces cerevisiae*. *Biochem J* *330 (Pt 2)*, 611-614.
- Ntambi, J. M., and Miyazaki, M. (2004). Regulation of stearoyl-CoA desaturases and role in metabolism. *Prog Lipid Res* *43*, 91-104.
- Peyou-Ndi, M. M., Watts, J. L., and Browse, J. (2000). Identification and characterization of an animal delta(12) fatty acid desaturase gene by heterologous expression in *Saccharomyces cerevisiae*. *Arch Biochem Biophys* *376*, 399-408.
- Porte, D., Jr., Baskin, D. G., and Schwartz, M. W. (2005). Insulin signaling in the central nervous system: a critical role in metabolic homeostasis and disease from *C. elegans* to humans. *Diabetes* *54*, 1264-1276.
- Spychalla, J. P., Kinney, A. J., and Browse, J. (1997). Identification of an animal omega-3 fatty acid desaturase by heterologous expression in *Arabidopsis*. *Proc Natl Acad Sci U S A* *94*, 1142-1147.
- Stukey, J. E., McDonough, V. M., and Martin, C. E. (1990). The OLE1 gene of *Saccharomyces cerevisiae* encodes the delta 9 fatty acid desaturase and can be functionally replaced by the rat stearoyl-CoA desaturase gene. *J Biol Chem* *265*, 20144-20149.
- Watts, J. L., and Browse, J. (1999). Isolation and characterization of a Delta 5-fatty acid desaturase from *Caenorhabditis elegans*. *Arch Biochem Biophys* *362*, 175-182.
- Watts, J. L., and Browse, J. (2002). Genetic dissection of polyunsaturated fatty acid synthesis in *Caenorhabditis elegans*. *Proc Natl Acad Sci U S A* *99*, 5854-5859.

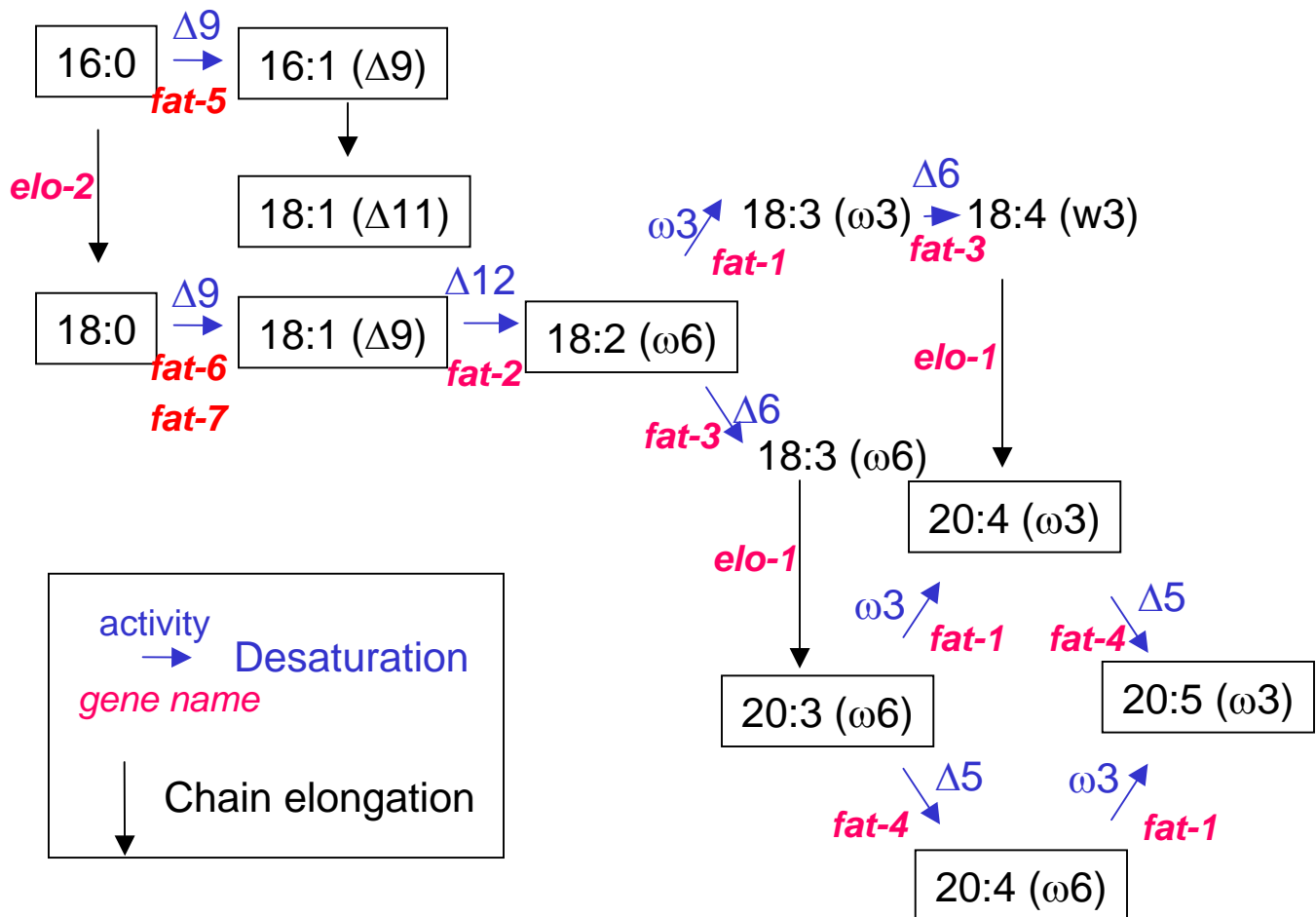


Figure 1. The pathway for fatty acid desaturation and elongation in *C. elegans*. Fatty acid desaturation and elongation in *C. elegans* produces about 10 major fatty acids (in boxes). The desaturases and their activities are *fat-1*: $\omega 3$, *fat-2*: $\Delta 12$, *fat-3*: $\Delta 6$, *fat-4*: $\Delta 5$, *fat-5*: $\Delta 9$, *fat-6*: $\Delta 9$, and *fat-7*: $\Delta 9$.

CHAPTER TWO

CHARACTERIZATION OF THE $\Delta 9$ FATTY ACID DESATURASES AND IDENTIFICATION OF NHR-80 AS A NOVEL REGULATOR OF $\Delta 9$ DESATURASE GENE EXPRESSION

Abstract

The $\Delta 9$ fatty acid desaturases are closely controlled enzymes that introduce a double bond between the 9th and 10th carbons of a saturated fatty acid (SFA) chain to generate a monounsaturated fatty acid (MUFA). The nematode *C. elegans* has a family of three $\Delta 9$ desaturases called FAT-5, FAT-6, and FAT-7. Production of MUFAs by these desaturases is the first step of the desaturation pathway and these MUFAs are incorporated into lipids such as phospholipids and triglycerides where they play essential roles in membrane fluidity and energy storage. Because of the importance of maintaining the proper ratio of SFA to MUFA in a cell, the $\Delta 9$ desaturases have extensive transcriptional regulation. We have identified a nuclear hormone receptor, NHR-80, in *C. elegans* that regulates $\Delta 9$ desaturase gene expression. The *nhr-80* mutants lack *fat-7* expression and also have a shift in the ratio of SFA to MUFA accumulating the substrate for FAT-7 desaturation. We have also examined the $\Delta 9$ desaturase single mutants and found that they are functionally redundant under standard laboratory growth conditions; however, analysis of the *fat-5;fat-6;fat-7* triple mutant and *nhr-80;fat-6* double mutant reveals that $\Delta 9$ desaturation and the MUFAs produced are essential for survival.

Introduction

Monounsaturated fatty acids (MUFAs) are key components of lipids, such as membrane phospholipids and triglycerides. As a constituent part of these lipids MUFAs play important roles in diverse cellular processes such as membrane function, energy storage, and signaling. The function of lipids in these processes is dependent on their fatty acid compositions, so tight control of MUFA synthesis is required. MUFAs are synthesized from saturated fatty acids (SFAs) by the $\Delta 9$ fatty acid desaturase enzymes (also known as stearyl-CoA desaturases or SCDs). Alteration in the ratio of MUFA to SFA is implicated in heart disease and cancer (Ntambi et al., 2004), the two leading causes of death in the United States (Smith, 2005). Thus, maintaining a proper ratio between MUFAs and SFAs is vital and the $\Delta 9$ desaturase genes are highly regulated to achieve control of this ratio.

The $\Delta 9$ fatty acid desaturases introduce a double bond between the 9th and 10th carbons in a SFA chain as the first step in the desaturation pathway. This is a required step for all further desaturation to generate polyunsaturated fatty acids. The $\Delta 9$ desaturases have four transmembrane domains that keep them anchored in the ER membrane (Nakamura and Nara, 2004). They also contain three histidine boxes and other conserved histidine residues that are necessary for activity because they coordinate two iron molecules at the active site (Shanklin et al., 1994). The reaction also requires oxygen and the cofactors cytochrome *b*₅, NADH, and NADH-cytochrome *b*₅ reductase. In eukaryotes, the $\Delta 9$ desaturases are ubiquitous enzymes found in organisms from yeast to humans.

The yeast $\Delta 9$ desaturase is called Ole1p and mutants that lack this activity are not able to survive without exogenous supplementation of unsaturated fatty acids (Stukey et al., 1989). Mice have four $\Delta 9$ desaturases, SCD1-4, each having a unique expression pattern but similar substrate specificity (Nakamura and Nara, 2004). Mutant analysis has revealed distinct roles for SCD1 and SCD2. SCD1 is important for adult energy metabolism and lipid synthesis (Ntambi et al., 2002), while SCD2 is involved in lipid synthesis during embryonic development (Miyazaki et al., 2005). Two $\Delta 9$ desaturase isoforms, hSCD1 and hSCD5, have been described in humans (Wang et al., 2005; Zhang et al., 1999). All of these organisms display complex regulation of the $\Delta 9$ desaturases due to the need to tightly control the ratio of SFA to MUFA for normal cellular function. For instance, the $\Delta 9$ desaturases in yeast, mice, and humans have decreased expression in response to unsaturated fatty acids (Choi et al., 1996; Ntambi, 1992; Zhang et al., 2001).

Expression of $\Delta 9$ desaturase genes is sensitive to a variety of environmental and endogenous signals. The environmental signals can include those in the diet such as polyunsaturated fatty acid (PUFA) consumption, which decreases $\Delta 9$ desaturase gene expression, and high carbohydrate consumption, which increases $\Delta 9$ desaturase gene expression (Ntambi and Miyazaki, 2004). They can also include environmental conditions such as temperature, which causes an increase in $\Delta 9$ desaturase gene expression in poikilotherms (Tiku et al., 1996). The internal signals include hormones such as leptin, which causes a decrease in $\Delta 9$ desaturase gene expression and insulin, which causes an increase in $\Delta 9$ desaturase gene expression (Ntambi and Miyazaki, 2004).

Two important transcription factors, SREBP and PPAR α , have also been identified as regulators of $\Delta 9$ desaturase gene expression in mammals (Nakamura and

Nara, 2004). SREBP is a transcription factor originally implicated in cholesterol metabolism (Brown and Goldstein, 1997) that activates expression of $\Delta 9$ desaturases (Tabor et al., 1998). PPAR α is one of a family of nuclear hormone receptors, the peroxisome proliferator activated receptors, that, upon ligand binding, acts as a heterodimer with the retinoid X receptor to induce transcription of target fat metabolism genes (Chawla et al., 2001). PPAR α , like all nuclear hormone receptors, contains a hydrophobic pocket for ligand binding and a DNA binding domain for interacting with the promoters of target genes. The targets of PPAR α include genes for the β -oxidation enzymes, the $\Delta 9$ desaturases, and other fatty acid desaturases (Gulick et al., 1994; Miller and Ntambi, 1996). The other members of the PPAR family, PPAR δ and PPAR γ , are also involved in regulation of fat metabolism, (Michalik et al., 2004). These regulators have unique roles due to differences in their gene expression patterns and regulatory activities.

Recently, in *C. elegans* the nuclear hormone receptor NHR-49 was shown to be an important regulator of fatty acid metabolism (Van Gilst et al., 2005a). NHR-49 is a member of the HNF4 class of nuclear hormone receptors and like NHR-49 in *C. elegans*, HNF-4 α is a regulator of lipid metabolism in mammals (Sampath and Ntambi, 2005). The *nhr-49* mutants have increased levels of the saturated fatty acid 18:0, higher fat accumulation, and a shorter lifespan than wild-type animals. NHR-49 is also involved in regulating the expression of the *C. elegans* $\Delta 9$ desaturase genes and is required for inducing *fat-7* expression in well-fed animals (Van Gilst et al., 2005b). *C. elegans* has 284 nuclear hormone receptors and the few that have been examined reveal diverse roles in many aspects of biology (Sluder and Maina, 2001); however, other than NHR-49 no

nuclear hormone receptors have been identified as regulating genes of fatty acid metabolism such as those encoding the $\Delta 9$ desaturases (Van Gilst et al., 2005a).

Expression of the *C. elegans* $\Delta 9$ fatty acid desaturases in yeast revealed that FAT-5 had unusual substrate preference. Most characterized $\Delta 9$ desaturases, including FAT-6 and FAT-7, are most active using 18:0 as a substrate but the *C. elegans* FAT-5 uses 16:0 preferentially. FAT-5 desaturates 16:0 to 16:1 $\Delta 9$ which is elongated to 18:1 $\Delta 11$. This accumulates and is the most abundant fatty acid in *C. elegans*. FAT-6 and FAT-7 do have some activity on 16:0 but are mostly responsible for desaturation of 18:0 to 18:1 $\Delta 9$, which is the substrate for further desaturation and elongation to create all of the PUFAs in *C. elegans*. *C. elegans* synthesizes a wide-range of fatty acids using a $\Delta 12$ desaturase, an $\omega 3$ desaturase, a $\Delta 5$ desaturase, and a $\Delta 6$ desaturase; however, these desaturase activities are satisfied by a single gene for each, while the $\Delta 9$ desaturase activity has three genes (Watts and Browse, 2002). Beyond the substrate specificity little is known about the roles of the *C. elegans* $\Delta 9$ desaturases.

C. elegans is a powerful model for studying many complex biological processes and is proving to be a good model for investigating fat metabolism. In addition to the small size, rapid lifecycle and other characteristics that make it a good model in general, *C. elegans* has several features important in the study of fat metabolism. *C. elegans* synthesizes a complex range of fatty acids but can also incorporate dietary fatty acids into lipids, allowing researchers to modify the fatty acid composition of live animals. In an RNAi screen many genes were identified that altered fat storage, including some with mammalian homologues known to function in fat metabolism (Ashrafi et al., 2003). In addition, there are many pathways known to regulate fat storage in both nematodes and

mammals such as the insulin-signaling pathway (Murphy et al., 2003). Despite these similarities, much remains to be described about fatty acid metabolism in *C. elegans*.

We decided to characterize the $\Delta 9$ desaturases of *C. elegans* because of the crucial role of these enzymes in the energy metabolism pathway. Many important biological processes have been evolutionarily conserved and are found in both *C. elegans* and humans. Because *C. elegans* is simpler and easier to manipulate experimentally we hope that we can gain understanding about the $\Delta 9$ desaturases and their regulation and apply that knowledge to understanding human energy metabolism.

We have identified a second nuclear hormone receptor, NHR-80, necessary for normal expression of the $\Delta 9$ fatty acid desaturases. Mutations in this transcription factor cause a change in the ratio of SFAs to MUFAs. In this paper, we also show that the $\Delta 9$ fatty acid desaturases have redundant but essential functions in *C. elegans*. This research provides a vital component to our understanding of fatty acid metabolism using *C. elegans* as a model.

Results and Discussion

Identification of NHR-80 as a regulator of fatty acid metabolism

In our search to identify the desaturases and elongases involved in generation of PUFAs in *C. elegans* we performed a genetic screen and isolated mutants with altered fatty acid profiles (Watts and Browse, 2002). In the process of identifying the molecular nature of one mutation (Appendix 1), we used RNAi to knockdown 156 ORFs at the end of Chromosome III to determine the fatty acid composition of animals when those genes were inactivated. We found an RNAi clone, *nhr-80*, that caused *C. elegans* to accumulate increased levels of 18:0. NHR-80 is a member of the nuclear hormone receptor family of transcription factors in *C. elegans* (Miyabayashi et al., 1999). To further characterize this gene we obtained the *nhr-80(tm1011)* mutant line. This mutant has a 446 bp deletion that eliminates half of the nucleotides in the second exon and all of the third exon (Figure 1A) and is very likely a null allele. Like the *nhr-80(RNAi)* worms, these mutants also show an accumulation of 18:0 and reduction of 18:1 Δ 9 (Figure 2) indicating that NHR-80 may be essential for normal fatty acid desaturation. In the *nhr-80* mutants 18:0 accounts for about 9.4% of the total fatty acids and 18:1 Δ 9 accounts for 2.3% as compared with 6.1% and 3.3%, respectively, in the wild type. The difference between these fatty acids in the *nhr-80* mutants and wild-type animals is significant with P values of less than 0.01 for both fatty acids. This is similar to the increase in 18:0 accumulation seen in the *nhr-49* mutants. In those mutants the ratio of 18:0 to 18:1 Δ 9 was 4.3 compared to a ratio of 1.9 in wild-type animals (Van Gilst et al., 2005a). In our experiments with the *nhr-80* mutants we see a ratio of 4.6 compared to the wild-type ratio

of 2.2. The *nhr-80* mutants are viable and fertile indicating this change in fatty acid composition, though significant, does not affect essential functions of the animal.

Although two nuclear hormone receptor mutant lines, *nhr-49* and *nhr-80*, show increased 18:0 as compared with wild-type worms, not all nuclear hormone receptor mutants cause these changes in fat metabolism (Van Gilst et al., 2005a). NHR-80 can join NHR-49 in a family of *C. elegans* nuclear hormone receptors involved in fat metabolism, perhaps similar to the PPAR family in mammals. HNF4 α is another nuclear hormone receptor involved in lipid metabolism in mammals and is derived from the same ancestral gene as NHR-80 and NHR-49. In fact, 269 of the 284 *C. elegans* nuclear hormone receptors are derived from this HNF4 ancestor (Robinson-Rechavi et al., 2005) but not all of these receptors are involved in fat metabolism.

In addition to the change in fatty acid composition, the *nhr-49* mutants also displayed an increase in fat storage by Nile red staining (Van Gilst et al., 2005a). We tested fat storage in the *nhr-80* mutants by characterizing the percent triglycerides in the total lipids. In the *nhr-80* mutants triglycerides made up 44(+/-1)% of the total lipids as compared to 45(+/-1)% in wild-type indicating no increase in fat storage. However, the *nhr-80* mutants do have an altered fatty acid profile highlighting a role for NHR-80 in the regulation of fatty acid metabolism in *C. elegans*.

NHR-80 is required for expression of the $\Delta 9$ desaturases

As NHR-80 is a transcription factor expressed in the intestine (Miyabayashi et al., 1999), the major site of fat metabolism in *C. elegans*, the increased 18:0 accumulation in the *nhr-80* mutants may be due to a misregulation of the $\Delta 9$ fatty acid desaturase genes. To test this we used quantitative PCR (QPCR) and found that expression of all three $\Delta 9$

desaturases was decreased in the *nhr-80* mutants relative to wild-type for eight experimental replicants. Indeed, *fat-7* expression was almost completely eliminated in the *nhr-80* mutants, while *fat-5* expression was decreased by half (Figure 3A).

To see if the expression pattern of *nhr-80* overlapped with the expression pattern of the $\Delta 9$ desaturases we created two GFP-fusion expressing lines for each of the $\Delta 9$ desaturase genes. Like NHR-80, all three $\Delta 9$ desaturases were expressed in the intestine in all four larval stages and adult worms (Figure 3B). The *fat-5* promoter::GFP expressing lines showed additional expression in the pharynx and tail cells. The *fat-6* whole gene::GFP expressing lines had expression in the hypodermis.

To confirm the regulation of the $\Delta 9$ desaturases by NHR-80, GFP expression lines were grown on *nhr-80(RNAi)* bacteria. Transformed adults were allowed to lay eggs on *nhr-80(RNAi)* and control bacteria. The adults were removed and about twenty of the progeny were examined for GFP expression after four days of growth (Figure 3B). Expression of *fat-7* whole gene::GFP was completely eliminated by the RNAi treatment. Expression of *fat-5p*::GFP and *fat-6wg*::GFP was also decreased but only in the intestine. The elimination of *fat-7* expression may account for the changes in fatty acid composition in the *nhr-80* mutant. FAT-7 is a $\Delta 9$ desaturase that converts 18:0 to 18:1 $\Delta 9$. The *nhr-80* mutants lack expression of this enzyme and accumulate the substrate and are depleted in the product.

Like the *nhr-80* mutants, the *nhr-49* mutants showed an increased level of 18:0 accumulation and a decrease in expression of the $\Delta 9$ fatty acid desaturase genes by QPCR with *fat-5* and *fat-7* as the most reduced (Van Gilst et al., 2005a). However, the *nhr-49* mutants were also reported to have an increased amount of fat storage possibly

due to a decrease in expression of the fatty acid β -oxidation genes *acs-2* and *ech-1*. We tested the expression of these genes in the *nhr-80* mutants and found that there was no change in expression levels relative to wild-type expression (data not shown). This is consistent with the normal level of fat storage seen in the *nhr-80* mutants. Though both NHR-49 and NHR-80 are required for *fat-7* expression, they seem to have different functions in fatty acid metabolism in *C. elegans*.

***nhr-80* mutants do not die early like *nhr-49* mutants**

It has been suggested that shifts in the ratio of SFA to MUFA in *C. elegans* may lead to a decreased lifespan, as seen with the increase in 18:0 accumulation in the *nhr-49* mutants and their short lifespan (Van Gilst et al., 2005a). We examined the lifespan of the *nhr-80* mutants and found that they may have slightly shorter lifespans than wild-type but live considerably longer than *nhr-49* mutants. The average lifespan of the *nhr-80* mutant was 12.5 +/-0.5 days as compared to 13.9 +/-0.4 days in wild-type animals and 8.2 +/-0.2 days in *nhr-49* mutants while grown at 25°C. While there is a significant difference between the lifespan of *nhr-80* mutants and wild-type animals (P=0.03), there is also a significant difference between the lifespan of *nhr-80* mutants and *nhr-49* mutants (P<0.01). The early death of the *nhr-49* does not seem to be caused solely by an elimination of *fat-7* expression or an increase in 18:0 accumulation as *nhr-80* mutants also show these characteristics without a dramatically shortened lifespan.

$\Delta 9$ fatty acid desaturases are redundant under standard growth conditions

Because of their central role in *C. elegans* fatty acid desaturation we decided to characterize the $\Delta 9$ desaturase single mutants. We obtained *fat-5(tm420)* and *fat-6(tm331)* and *fat-7(wa36 and wa37)* (Figure 1B). The *fat-7(tm326)* allele is available but

our work with this allele led us to believe that a more serious genetic disruption had occurred that affected genes other than *fat-7* (Appendix 2). The *fat-5* allele has a 779 bp deletion early in the coding sequence that eliminates two of the conserved histidine boxes and two of the transmembrane domains. The *fat-6* allele has a 1232 bp deletion and a 428 bp insertion. The deletion is early in the coding sequence and also eliminates two of the conserved histidine-rich regions and two transmembrane domains. No functional protein could be produced from either of these mutations. The *fat-7* alleles were found by TILLING (Targeting Induced Local Lesions IN Genomes) and are single base pair changes. The *fat-7(wa36)* allele is a C to T mutation that leads to a premature stop codon. The truncated protein produced from this allele is nonfunctional because it lacks two transmembrane domains and one of the conserved histidine boxes required for $\Delta 9$ desaturation activity (Shanklin et al., 1994). The *fat-7(wa37)* allele is also likely to have no functional FAT-7 as the C to T mutation replaces a conserved histidine with tyrosine. Heterologous expression of this allele in mutant yeast that lack their $\Delta 9$ desaturase (*ole1* mutants) failed to complement the *ole1* mutant yeast whereas expression of wild-type *fat-7* did complement (Watts and Browse, 2000). Phenotypic characterization including fatty acid composition and lifespan with *fat-7(wa37)* showed no difference from *fat-7(wa36)* so only data from *fat-7(wa36)* is reported here.

The $\Delta 9$ desaturase mutants show subtle differences from wild-type in their fatty acid profile when grown on an OP50 bacterial lawn on NGM plates at 20°C (Figure 4A-C). Compared to wild-type (4%), the *fat-5* mutants are significantly decreased in their composition of 16:1 $\Delta 9$ (3%), which is the produce of FAT-5 desaturation. The *fat-5* mutants are also significantly increased in their accumulation of 18:2 $\omega 3$ (6%) compared

to wild-type (5%), perhaps due to compensation in these mutants. The *fat-6* mutants are significantly increased in their accumulation of 18:0 (9%) over wild-type (7%) and their accumulation of 18:1 Δ 11 (18%) over wild-type (13%). The *fat-6* mutants also accumulate significantly less 16:1 Δ 9 (3%) than wild-type (4%). The preferred substrate for FAT-6 is 18:0 so its accumulation in the *fat-6* mutants is understandable. Also in the *fat-6* mutants FAT-5 may be more active desaturating 16:0 to 16:1 Δ 9 which is then elongated to 18:1 Δ 11, which may explain the increase in 18:1 Δ 11. The decrease in 16:1 Δ 9 could be explained by an activation of the elongase that converts 16:1 Δ 9 to 18:1 Δ 11. The *fat-7* mutants also show this significant decrease in 16:1 Δ 9 accumulation (3%) compared to wild-type (4%), which could be for the same reason. Though these changes are significant they are not dramatic changes in fatty acid composition in the Δ 9 desaturase single mutants.

These mutants are indistinguishable from wild-type in other characteristics tested such as growth rate, reproduction, and behavior. The lack of phenotype indicates that the Δ 9 desaturases may have redundant functions under standard growth conditions. We looked at expression of the Δ 9 desaturase genes in the Δ 9 desaturase mutants (Figure 5). In the *fat-6* mutants, *fat-7* expression is increased 3.8-fold over wild-type and *fat-5* expression is increased 2.6-fold over wild-type. In the *fat-7* mutant expression of *fat-6* and *fat-5* is also slightly increased over wild-type. The *fat-5* mutant shows very little difference from wild-type in *fat-6* and *fat-7* expression. The major fatty acid produced by FAT-5 is 16:1 Δ 9, which is elongated to 18:1 Δ 11. The *E. coli* used as a food source also produce these fatty acids. It is likely that *fat-5* expression is not essential due to the attainment of 16:1 Δ 9 and 18:1 Δ 11 from the *E. coli* diet.

Axenic growth reveals substrate specificity of the $\Delta 9$ desaturases

The standard OP50 *E. coli* on which *C. elegans* are maintained in the laboratory contain SFAs and MUFAs such as 16:1 $\Delta 9$ and 18:1 $\Delta 11$, but not 18:1 $\Delta 9$, in their membrane. When worms eat these bacteria they incorporate those fatty acids in their lipids. To avoid this bacterial source of fatty acids we grew *C. elegans* in axenic media. This is a liquid media that provides amino acids, vitamins, growth factors, and heme (Houthoofd et al., 2002). The growth rate of wild-type worms is significantly slower under the axenic growth conditions with no dietary source of fatty acids, as is their fatty acid profile. They accumulate less of the fatty acids found in the bacteria and none of the fatty acids found exclusively in bacteria. Wild-type animals grown in axenic culture also produce fewer PUFAs. The $\Delta 9$ desaturase mutants also show greater differences in fatty acid composition than those grown on OP50 (Figure 4D-F). The *fat-5* mutant fatty acids are comprised of 4% 18:1 $\Delta 11$ compared with 19% in wild-type in axenic culture. The *fat-6* mutant fatty acids are comprised of 13% 18:1 $\Delta 9$ compared with 24% in wild-type in axenic culture. The fatty acid composition of *fat-7* mutants do not differ from wild-type, indicating that *fat-6* can completely compensate for *fat-7* in axenic culture. The dramatic reduction of 16:1 $\Delta 9$ /18:1 $\Delta 11$ fatty acids in *fat-5* mutants and 18:1 $\Delta 9$ in *fat-6* mutants is the first evidence that these enzymes have the same substrate specificity in *C. elegans* as they do when expressed in yeast (Watts and Browse, 2000). The FAT-7 $\Delta 9$ desaturase does not seem to play an important role in maintaining proper fatty acid composition under axenic conditions.

Single $\Delta 9$ fatty acid desaturase mutants have no early death phenotype.

Previous studies investigating the $\Delta 9$ desaturases have used RNAi to deplete *fat-7* expression and has suggested roles for the $\Delta 9$ desaturase genes in aging (Murphy et al., 2003; Van Gilst et al., 2005a). However, the knock-out mutants used in our experiment do not show the early death phenotype reported in the RNAi studies (Figure 6). The average lifespan of the *fat-5* mutants is 15.8 +/- 0.6 days, the *fat-6* mutant is 14.2 +/-0.5 days, and the *fat-7* mutant is 15.0 +/-0.5 days as compared with a lifespan of 13.9 +/-0.4 days in wild-type animals. The *fat-5* mutant does have a slight but significant ($P < 0.01$) increase in lifespan over wild-type, while the *fat-6* and *fat-7* mutants are not significantly different from wild-type in lifespan. The knock-out mutants have a different aging phenotype than the *fat-7(RNAi)* grown worms. The RNAi phenotype observed is likely due to a cross-over effect (Appendix 3) as *fat-6* and *fat-7* have 84% identity at the nucleotide level including many regions of more than 20 nucleotides with 100% identity. The RNAi could also be affecting *fat-5* as it has 61% identity with *fat-7* including several regions more than 20 nucleotides in length with only one mismatch. Because the single mutants do not show the severe phenotypes seen with RNAi it indicates that the RNAi is affecting all three $\Delta 9$ desaturases due to transitive RNAi (Dillin, 2003).

$\Delta 9$ fatty acid desaturases are necessary for survival.

Because the $\Delta 9$ desaturase genes appear to compensate for each other we constructed a *fat-5;fat-6;fat-7* triple mutant lacking all three $\Delta 9$ desaturases. We crossed *fat-6(tm331);fat-7(wa36)* hermaphrodites (Chapter 4) with *fat-5(tm420);fat-7(wa36)* males (Chapter 3) on plates supplemented with 18:1 $\Delta 9$. The F1 generation was moved to new 18:1 $\Delta 9$ supplemented plates and their progeny were also moved to 18:1 $\Delta 9$

supplemented plates. After the F2 generation reproduced, the adults were harvested for single worm PCR (SWPCR) to determine the genotype (Wicks et al., 2001). The *fat-5* and *fat-6* mutations were monitored using the difference in amplicon size between wild-type and mutant alleles due to the large deletions. The wild-type products were 1100 bp for *fat-5* and 1457 bp for *fat-6* compared with the mutant products of 321 bp and 652 bp, respectively. All cross-progeny would be homozygous for the *fat-7* single base pair mutation. We generated a *fat-5;fat-6/+;fat-7* line with this supplementation regimen. To create a homozygous triple mutant we supplemented the *fat-5;fat-6/+;fat-7* line with a combination of 18:1 Δ 9, 18:2 ω 6, and 20:5 ω 3. We identified the *fat-5;fat-6;fat-7* triple mutant and moved the worms to plates without fatty acid supplementation. These mutants have no endogenous production of MUFAs and do not survive without dietary fatty acid supplementation. When these worms are removed from supplementation they become thin, lose movement, and arrest developmentally. The yeast Δ 9 desaturase mutant, *ole1*, is also unable to grow without supplementation (Stukey et al., 1989). The *fat-5;fat-6;fat-7* triple mutant is the first multicellular organism generated that lacks all endogenous Δ 9 desaturase ability and will be useful in further study of the roles of MUFAs in an organism.

To examine genetic interaction between *nhr-80* and *fat-6*, the most highly expressed Δ 9 desaturase, we constructed the *fat-6;nhr-80* double mutant. We crossed *fat-6* males with *nhr-80* hermaphrodites on 18:1 Δ 9 supplemented plates and isolated the the F1 generation onto new supplemented plates. After confirming the F1 generation with SWPCR, the F2s were moved to fresh 18:1 Δ 9 supplemented plates and allowed to reproduce. We used SWPCR to identify *fat-6;nhr-80* double mutants growing on

supplemented plates. The *nhr-80* wild-type allele generated a PCR product of 745 bp, whereas the *nhr-80(tm1011)* mutant allele generated a product 298 bp in length, a difference easily visualized on a 0.8% agarose gel. When we removed the *fat-6;nhr-80* double mutants from supplementation we found that these worms also would not survive without dietary fatty acid supplementation. To study this interaction further we used RNAi to look at survival for *fat-5*, *fat-6*, and *fat-7* on *nhr-80(RNAi)* because *nhr-80(RNAi)* phenocopies the *nhr-80* mutant well. The *fat-6* mutants when grown on *nhr-80(RNAi)* become thin, slow growing, and reproductively inviable (Figure 7A). They also accumulate very high levels of 18:0 (Figure 7B). The *fat-6* mutants grown on *nhr-80(RNAi)* accumulate 34% of their fatty acids as 18:0 as compared to 9% when *fat-6* is grown on control bacteria or 14% when wild-type worms are grown on *nhr-80(RNAi)* bacteria. Though 18:0 does accumulate in the *fat-5* and *fat-7* mutants grown on *nhr-80(RNAi)* as in wild-type, the difference is not as dramatic (Figure 7B) and they do not show a synthetic lethality (Figure 7A).

One explanation for the synthetic lethality of *fat-6;nhr-80* double mutants is that NHR-80 is required for the increased *fat-5* and *fat-7* expression in the *fat-6* mutant. In the *fat-6* mutant *fat-5* and *fat-7* are increased in expression to compensate for the lack of *fat-6*. In the *nhr-80* single mutant there is enough expression of *fat-6* and *fat-5* to compensate for the lack of *fat-7*. The *fat-6;nhr-80* double mutants lack *fat-6* and *fat-7* and have reduced amounts of *fat-5* so they cannot survive, similar to the *fat-5;fat-6;fat-7* triple mutant. They accumulate higher levels of 18:0 because they have very reduced $\Delta 9$ desaturase activity. To test this we looked at expression of the $\Delta 9$ desaturases in the $\Delta 9$ desaturase mutants grown on *nhr-80(RNAi)*. Indeed, expression of *fat-7* in the *fat-6;nhr-*

80(RNAi) is only about 10% of the expression of *fat-7* in the *fat-6* mutants grown on control bacteria (Figure 7C). We graphed the relative expression values setting *fat-6* expression in wild-type worms grown on control bacteria as 100%. In wild-type worms on control bacteria *fat-6* is the highest expressed $\Delta 9$ desaturase gene and *fat-5* and *fat-7* are expressed around 5% of the level of *fat-6*. When the wild-type worms are grown on *nhr-80(RNAi)* we see the same decrease in $\Delta 9$ desaturase gene expression seen in the *nhr-80* mutants. Comparing the *fat-5* and *fat-7* mutants grown on control with those grown on *nhr-80(RNAi)* we also see a decrease in $\Delta 9$ desaturase gene expression. However, the biggest difference is seen in the *fat-6* mutants. When these animals are grown on control bacteria *fat-7* is increased in expression and has a relative expression of 239%. When *fat-6* is grown on *nhr-80(RNAi)* the *fat-7* relative expression is only 22%. Thus NHR-80 is required for the upregulation of *fat-7* expression in situations where higher *fat-7* levels are necessary and is a critical new regulator of fatty acid metabolism.

Materials and Methods

Culture of nematodes

Unless otherwise noted, animals were grown according to standard methods with OP50 *E. coli* as a food source (Wood, 1988). The *nhr-80(RNAi)* construct, as well as the others used in the screen of Chromosome III, are from the Ahringer RNAi library (Kamath and Ahringer, 2003) and were used as described (Kamath et al., 2001). As a control for RNAi experiments, nematodes were grown on HT115 *E. coli* transformed with an L4440 empty vector plasmid. The axenic culture media consisted of 3% soy peptone, 3% yeast extract, 0.5 mg/ml hemoglobin in 1M KOH, and 20% ultra-high temperature pasteurized skim milk (Houthoofd et al., 2002). Worms were grown in this liquid culture at room temperature with constant shaking.

Fatty acid and lipid analysis

For fatty acid analysis, adult nematodes were washed from plates and allowed to settle. The excess water was removed from the worm pellet and H₂SO₄ was added to generate fatty acid methyl esters (FAMES). After incubation at 80°C for 1 hour the samples were cooled and the FAMES were extracted by adding water and hexane. The hexane containing the FAMES was sampled for determination of fatty acid composition by gas chromatography on an SP-2380 fused silica capillary column (Supelco) using an Agilent 6890 series GC (Watts and Browse, 2002).

For lipid analysis, about 0.5 ml of adult nematodes were collected in a glass tube and frozen. Then 5 ml of cold CHCl₃:CH₃OH (1:1) was added and the samples were mixed. After overnight incubation at -20°C, 2.2 ml Hajra's solution (0.2M H₃PO₄, 1M KCl) was added and the sample was mixed thoroughly. The solution was centrifuged for one

minute to separate the phases. The lower phase was sampled to a new tube and 0.5 ml CHCl₃ was added to the original sample to extract the lower phase again. The combined CHCl₃ extracts were evaporated down to 100 µl using Argon. 200 µl of CHCl₃ was added to wash the sides of the tube and the samples were evaporated down to 100 µl again. CHCl₃ was added to bring the volume to 200 µl. The TLC plates were activated by incubation at 110°C for one hour and fifteen minutes. The samples were loaded onto the TLC plates and the plates were run with the solvent 65 ml chloroform, 43 ml methanol, 3 ml water, 2.5 ml acetic acid until the solvent front is three-fourths of the way up the plate. The plate was dried and a new solvent of 80 ml hexane, 20 ml diethyl ether, 2 ml acetic acid is added. This plate was run until the solvent front at the top of the plate. The marker lanes were visualized using iodine and the corresponding bands for TAG, PE/PI, PS, and PC in the silica gel were scraped into individual tubes. To quantitate 50 µg of 15:0 free fatty acid was added to each tube as an internal standard and fatty acid analysis was performed as described above (Ashrafi et al., 2003).

QPCR analysis

Adult nematodes were harvested and frozen in liquid nitrogen. RNA was prepared using TRIzol Reagent (Invitrogen). A DNA-FREE RNA kit (Zymo Research) was used for Dnase treatment and purification. After quantification, one µg of RNA was used in a reverse-transcription reaction with SuperScriptIII (Invitrogen) to generate cDNA. Primer sequences for the $\Delta 9$ desaturase and reference genes were designed using PrimerQuest software at www.idtdna.com. Other primer sequences were obtained from Dr. Marc Van Gilst (Van Gilst et al., 2005a). The PCR mixture consisted of 0.3 µM primers, cDNA, ROX, and 1x SYBR green mix (Invitrogen Platinum SYBR green qPCR Supermix

UDG). The QPCR was run and monitored on a MX3000P (Stratagene). Relative abundance was determined using the $\Delta\Delta C_t$ method and reference genes such as *tbb-2* and *ubc-2* to control for template levels (Wong and Medrano, 2005).

Construction of GFP fusions and microinjection.

Fusion PCR was used to create translational *fat-5*, *fat-6* and *fat-7* GFP constructs. The promoters and coding sequences of *fat-6* and *fat-7* and the promoter and first exon of *fat-5* were amplified from genomic DNA. The upstream regulatory region for *fat-5* was 4 kb, for *fat-6* was 2.6 kb and for *fat-7* was 3.0 kb. GFP was amplified from the Fire vector pPD95.75 including the entire coding sequence and a termination sequence. These PCR products were fused together in a final PCR using nested primers (Hobert, 2002). These fusions were microinjected into *lin-15* mutant *C. elegans* along with a rescuing plasmid, pJM23, containing the wild-type *lin-15* gene (Clark et al., 1994; Mello et al., 1991). Multiple independent lines of nematodes without the *lin-15* phenotype were selected and examined for GFP expression using fluorescence microscopy on an Olympus IX70 microscope. Images were captured using a Nikon Coolpix 990 digital camera.

Lifespan analysis

Aging experiments were performed on adult nematodes grown at 25°C. Worms were moved to plates containing 5-fluoro-2'-deoxyuridine (Sigma) at the fourth larval stage of development (L4). Live animals were assayed for movement in response to touch every 1-2 days (Apfeld and Kenyon, 1998).

Genotyping of *fat-5(tm420)*, *fat-6(tm331)*, *fat-7(wa36)*, and *nhr-80(tm1011)*

Single worm PCR (SWPCR) (Wicks et al., 2001) was used to determine the genotype of worms during crossing to generate a *fat-5;fat-6;fat-7* triple mutant line and a *fat-6;nhr-80*

double mutant line. Males and hermaphrodites were allowed to mate. The F1 generation was isolated and allowed to reproduce. Once the F2 generation had progeny the F2 adults were picked into worm lysis buffer (50 mM KCl, 10 mM Tris-HCl pH 8.3, 2.5 mM MgCl₂, 0.45% NP-40, 0.45% Tween 20, 0.01% gelatine, freshly added 60 µg/ml proteinase K) for SWPCR analysis. The worms in lysis buffer were frozen at -80°C for at least 10 minutes then heated to 60°C for 60 minutes to digest the worms. The proteinase K was inactivated by heating to 95°C for 20 minutes. For *fat-5(tm420)*, *fat-6(tm331)*, and *nhr-80(tm1011)* identification, a PCR mix (2.2 µl 10xPCR buffer, 0.44 µl of 10 µM dNTP, 0.88 µl of each 10 µM primer stock, 1 µl 60% sucrose, 1 µl 0.1% cresol red, 0.22 µl Takara Ex-Taq polymerase, and water to 20 µl) was then added to each reaction and *fat-5*, *fat-6*, and *nhr-80* were amplified in a standard PCR reaction using an MJ Research PTC-200 thermal cycler. Amplified products were run on a 0.8% agarose gel.

References

- Apfeld, J., and Kenyon, C. (1998). Cell nonautonomy of *C. elegans* daf-2 function in the regulation of diapause and life span. *Cell* 95, 199-210.
- Ashrafi, K., Chang, F. Y., Watts, J. L., Fraser, A. G., Kamath, R. S., Ahringer, J., and Ruvkun, G. (2003). Genome-wide RNAi analysis of *Caenorhabditis elegans* fat regulatory genes. *Nature* 421, 268-272.
- Brown, M. S., and Goldstein, J. L. (1997). The SREBP pathway: regulation of cholesterol metabolism by proteolysis of a membrane-bound transcription factor. *Cell* 89, 331-340.
- Chawla, A., Repa, J. J., Evans, R. M., and Mangelsdorf, D. J. (2001). Nuclear receptors and lipid physiology: opening the X-files. *Science* 294, 1866-1870.
- Choi, J. Y., Stuke, J., Hwang, S. Y., and Martin, C. E. (1996). Regulatory elements that control transcription activation and unsaturated fatty acid-mediated repression of the *Saccharomyces cerevisiae* OLE1 gene. *J Biol Chem* 271, 3581-3589.
- Clark, S. G., Lu, X., and Horvitz, H. R. (1994). The *Caenorhabditis elegans* locus lin-15, a negative regulator of a tyrosine kinase signaling pathway, encodes two different proteins. *Genetics* 137, 987-997.
- Dillin, A. (2003). The specifics of small interfering RNA specificity. *Proc Natl Acad Sci U S A* 100, 6289-6291.
- Gulick, T., Cresci, S., Caira, T., Moore, D. D., and Kelly, D. P. (1994). The peroxisome proliferator-activated receptor regulates mitochondrial fatty acid oxidative enzyme gene expression. *Proc Natl Acad Sci U S A* 91, 11012-11016.
- Hobert, O. (2002). PCR fusion-based approach to create reporter gene constructs for expression analysis in transgenic *C. elegans*. *Biotechniques* 32, 728-730.
- Houthoofd, K., Braeckman, B. P., Lenaerts, I., Brys, K., De Vreese, A., Van Eygen, S., and Vanfleteren, J. R. (2002). Axenic growth up-regulates mass-specific metabolic rate, stress resistance, and extends life span in *Caenorhabditis elegans*. *Exp Gerontol* 37, 1371-1378.
- Kamath, R. S., and Ahringer, J. (2003). Genome-wide RNAi screening in *Caenorhabditis elegans*. *Methods* 30, 313-321.

- Kamath, R. S., Martinez-Campos, M., Zipperlen, P., Fraser, A. G., and Ahringer, J. (2001). Effectiveness of specific RNA-mediated interference through ingested double-stranded RNA in *Caenorhabditis elegans*. *Genome Biol* 2, RESEARCH0002.
- Mello, C. C., Kramer, J. M., Stinchcomb, D., and Ambros, V. (1991). Efficient gene transfer in *C.elegans*: extrachromosomal maintenance and integration of transforming sequences. *Embo J* 10, 3959-3970.
- Michalik, L., Desvergne, B., and Wahli, W. (2004). Peroxisome-proliferator-activated receptors and cancers: complex stories. *Nat Rev Cancer* 4, 61-70.
- Miller, C. W., and Ntambi, J. M. (1996). Peroxisome proliferators induce mouse liver stearoyl-CoA desaturase 1 gene expression. *Proc Natl Acad Sci U S A* 93, 9443-9448.
- Miyabayashi, T., Palfreyman, M. T., Sluder, A. E., Slack, F., and Sengupta, P. (1999). Expression and function of members of a divergent nuclear receptor family in *Caenorhabditis elegans*. *Dev Biol* 215, 314-331.
- Miyazaki, M., Dobrzyn, A., Elias, P. M., and Ntambi, J. M. (2005). Stearoyl-CoA desaturase-2 gene expression is required for lipid synthesis during early skin and liver development. *Proc Natl Acad Sci U S A* 102, 12501-12506.
- Murphy, C. T., McCarroll, S. A., Bargmann, C. I., Fraser, A., Kamath, R. S., Ahringer, J., Li, H., and Kenyon, C. (2003). Genes that act downstream of DAF-16 to influence the lifespan of *Caenorhabditis elegans*. *Nature* 424, 277-283.
- Nakamura, M. T., and Nara, T. Y. (2004). Structure, function, and dietary regulation of delta6, delta5, and delta9 desaturases. *Annu Rev Nutr* 24, 345-376.
- Ntambi, J. M. (1992). Dietary regulation of stearoyl-CoA desaturase 1 gene expression in mouse liver. *J Biol Chem* 267, 10925-10930.
- Ntambi, J. M., and Miyazaki, M. (2004). Regulation of stearoyl-CoA desaturases and role in metabolism. *Prog Lipid Res* 43, 91-104.
- Ntambi, J. M., Miyazaki, M., and Dobrzyn, A. (2004). Regulation of stearoyl-CoA desaturase expression. *Lipids* 39, 1061-1065.
- Ntambi, J. M., Miyazaki, M., Stoehr, J. P., Lan, H., Kendziorski, C. M., Yandell, B. S., Song, Y., Cohen, P., Friedman, J. M., and Attie, A. D. (2002). Loss of stearoyl-CoA desaturase-1 function protects mice against adiposity. *Proc Natl Acad Sci U S A* 99, 11482-11486.

Robinson-Rechavi, M., Maina, C. V., Gissendanner, C. R., Laudet, V., and Sluder, A. (2005). Explosive lineage-specific expansion of the orphan nuclear receptor HNF4 in nematodes. *J Mol Evol* 60, 577-586.

Sampath, H., and Ntambi, J. M. (2005). Polyunsaturated fatty acid regulation of genes of lipid metabolism. *Annu Rev Nutr* 25, 317-340.

Shanklin, J., Whittle, E., and Fox, B. G. (1994). Eight histidine residues are catalytically essential in a membrane-associated iron enzyme, stearoyl-CoA desaturase, and are conserved in alkane hydroxylase and xylene monooxygenase. *Biochemistry* 33, 12787-12794.

Sluder, A. E., and Maina, C. V. (2001). Nuclear receptors in nematodes: themes and variations. *Trends Genet* 17, 206-213.

Smith, R. N. A. a. B. L. (2005). Deaths: Leading Causes for 2002. National Vital Statistics Report 53.

Stukey, J. E., McDonough, V. M., and Martin, C. E. (1989). Isolation and characterization of OLE1, a gene affecting fatty acid desaturation from *Saccharomyces cerevisiae*. *J Biol Chem* 264, 16537-16544.

Tabor, D. E., Kim, J. B., Spiegelman, B. M., and Edwards, P. A. (1998). Transcriptional activation of the stearoyl-CoA desaturase 2 gene by sterol regulatory element-binding protein/adipocyte determination and differentiation factor 1. *J Biol Chem* 273, 22052-22058.

Tiku, P. E., Gracey, A. Y., Macartney, A. I., Beynon, R. J., and Cossins, A. R. (1996). Cold-induced expression of delta 9-desaturase in carp by transcriptional and posttranslational mechanisms. *Science* 271, 815-818.

Van Gilst, M. R., Hadjivassiliou, H., Jolly, A., and Yamamoto, K. R. (2005a). Nuclear hormone receptor NHR-49 controls fat consumption and fatty acid composition in *C. elegans*. *PLoS Biol* 3, e53.

Van Gilst, M. R., Hadjivassiliou, H., and Yamamoto, K. R. (2005b). From The Cover: A *Caenorhabditis elegans* nutrient response system partially dependent on nuclear receptor NHR-49. *Proc Natl Acad Sci U S A* 102, 13496-13501.

Wang, J., Yu, L., Schmidt, R. E., Su, C., Huang, X., Gould, K., and Cao, G. (2005). Characterization of HSCD5, a novel human stearoyl-CoA desaturase unique to primates. *Biochem Biophys Res Commun* 332, 735-742.

Watts, J. L., and Browse, J. (2000). A palmitoyl-CoA-specific delta9 fatty acid desaturase from *Caenorhabditis elegans*. *Biochem Biophys Res Commun* 272, 263-269.

Watts, J. L., and Browse, J. (2002). Genetic dissection of polyunsaturated fatty acid synthesis in *Caenorhabditis elegans*. *Proc Natl Acad Sci U S A* 99, 5854-5859.

Wicks, S. R., Yeh, R. T., Gish, W. R., Waterston, R. H., and Plasterk, R. H. (2001). Rapid gene mapping in *Caenorhabditis elegans* using a high density polymorphism map. *Nat Genet* 28, 160-164.

Wong, M. L., and Medrano, J. F. (2005). Real-time PCR for mRNA quantitation. *Biotechniques* 39, 75-85.

Wood, W. B. (1988). *The Nematode Caenorhabditis elegans* (Cold Spring Harbor, NY, Cold Spring Harbor Laboratory Press).

Zhang, L., Ge, L., Parimoo, S., Stenn, K., and Prouty, S. M. (1999). Human stearoyl-CoA desaturase: alternative transcripts generated from a single gene by usage of tandem polyadenylation sites. *Biochem J* 340 (Pt 1), 255-264.

Zhang, L., Ge, L., Tran, T., Stenn, K., and Prouty, S. M. (2001). Isolation and characterization of the human stearoyl-CoA desaturase gene promoter: requirement of a conserved CCAAT cis-element. *Biochem J* 357, 183-193.

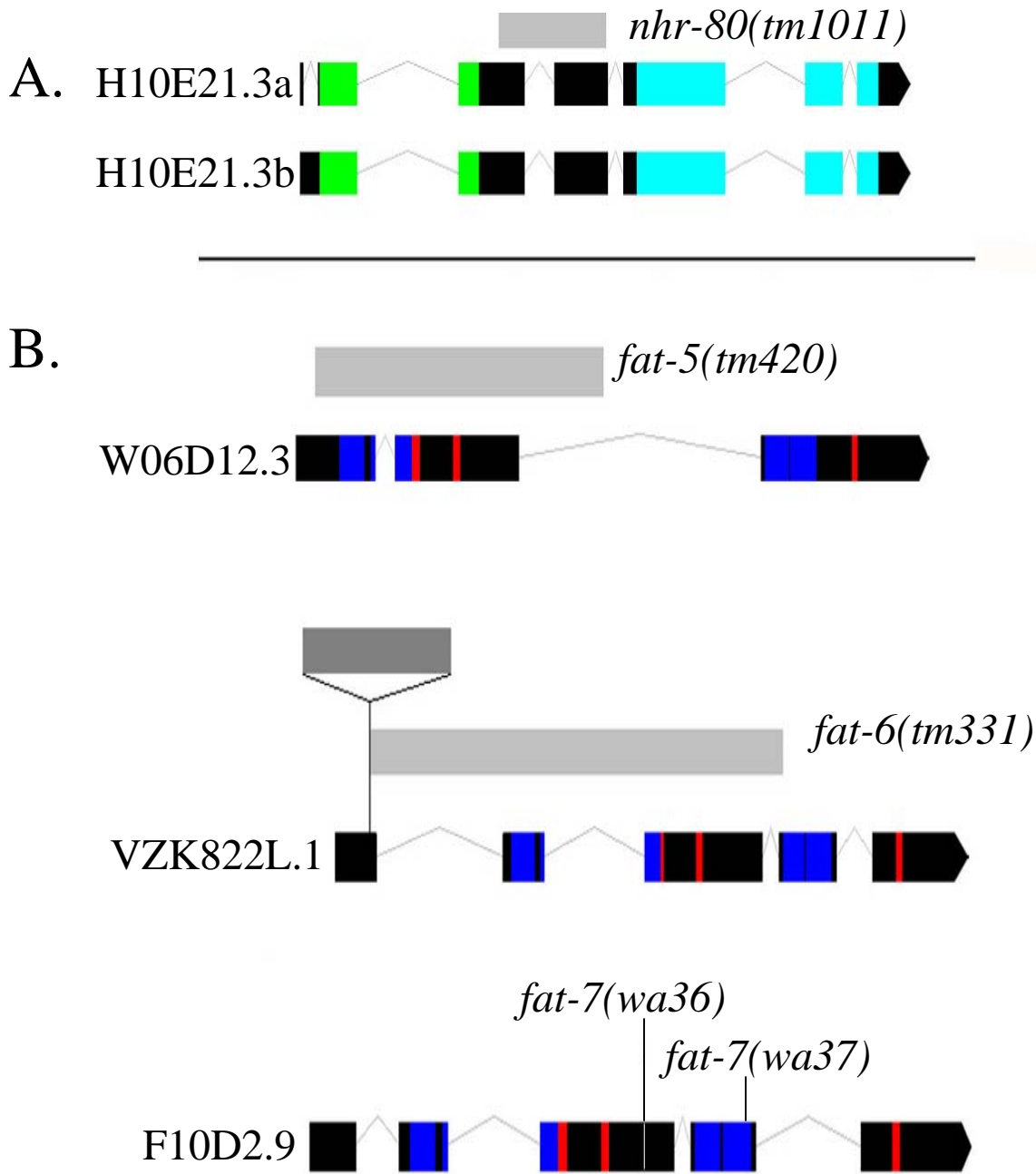


Figure 1. Diagram of *nhf-80*, *fat-5*, *fat-6*, and *fat-7* genes and mutations. **A.** *nhf-80*. Light grey bars indicate deletions, green boxes indicate zinc fingers, and light blue boxes indicate ligand binding domains. **B.** *fat-5*, *fat-6*, and *fat-7*. Light grey bars indicate deletions, dark grey bars indicate insertions, dark blue boxes indicate transmembrane domains, and red boxes indicate histidine boxes.

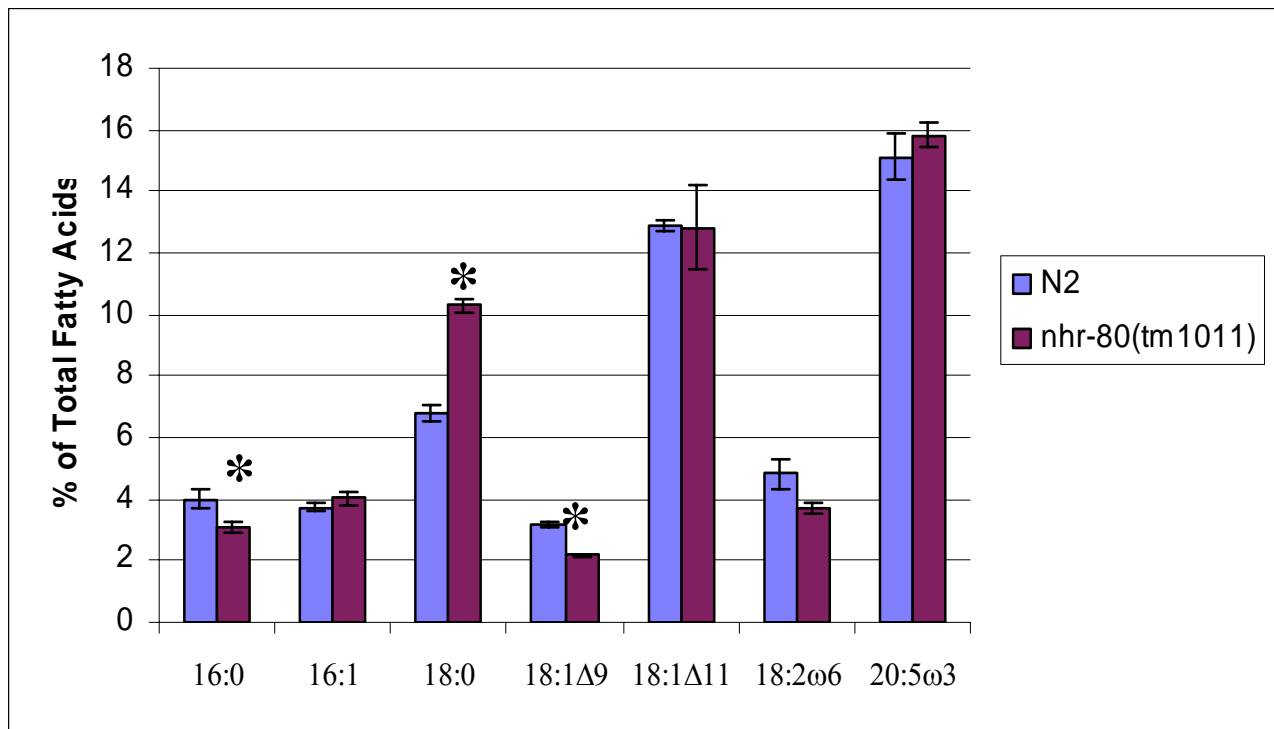


Figure 2. Fatty acid composition of *nhr-80*. Relative abundance of selected fatty acid species expressed as percentage of total fatty acid as determined by GC analysis. Error bars represent the standard error and asterisk indicate a significant difference from wild-type with P values <0.01.

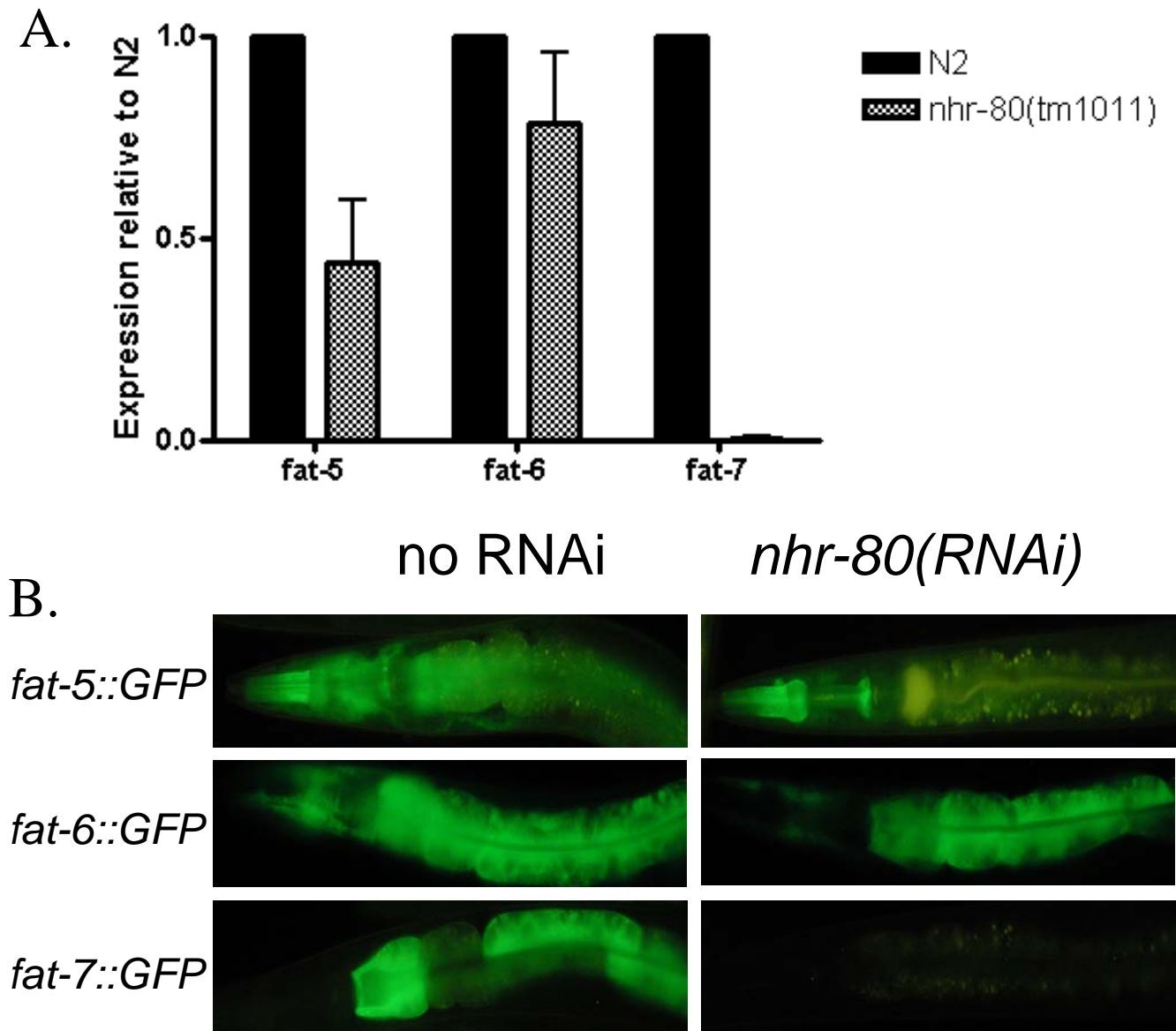


Figure 3. Expression of the $\Delta 9$ desaturases in *nhr-80*. **A.** Gene expression by RT-QPCR in the *nhr-80* mutant relative to N2 wild-type. Error bars represent standard error. **B.** $\Delta 9$ desaturase expressing lines grown on empty vector control bacteria or *nhr-80(RNAi)* bacteria for 3 days.

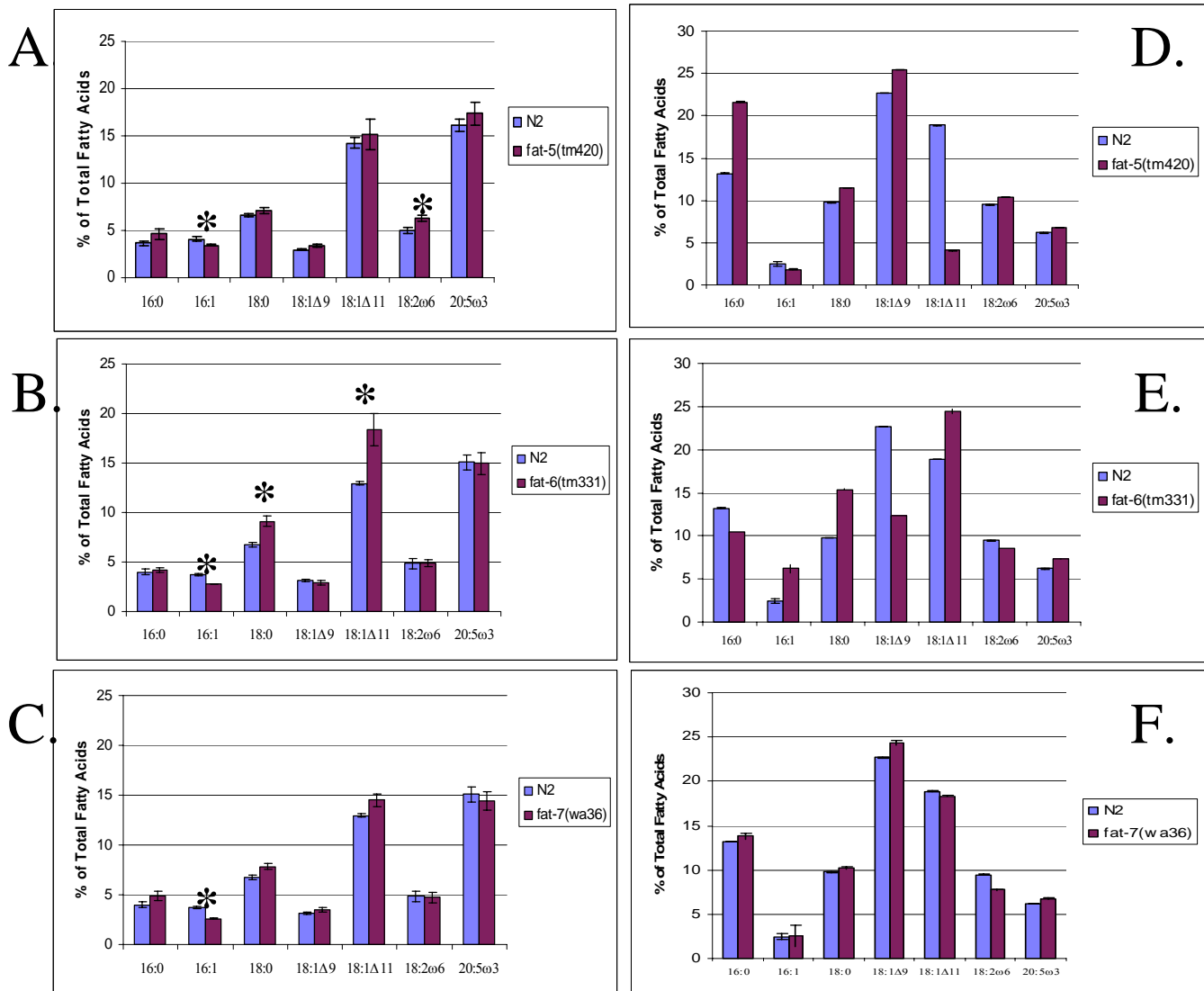


Figure 4. Fatty acid composition of the $\Delta 9$ desaturase mutants. **A.** Standard growth conditions for *fat-5* and N2 wild-type. **B.** Standard growth conditions for *fat-6* and N2 wild-type. **C.** Standard growth conditions for *fat-7* and N2 wild-type. **D.** Axenic growth conditions for *fat-5* and N2 wild-type. **E.** Axenic growth conditions for *fat-6* and N2 wild-type. **F.** Axenic growth conditions for *fat-7* and N2 wild-type. In all graphs relative abundance of selected fatty acid species is expressed as percentage of total fatty acid as determined by GC analysis. Error bars represent the standard error and asterisk in standard growth condition graphs indicate a significant difference from wild-type with P values < 0.01.

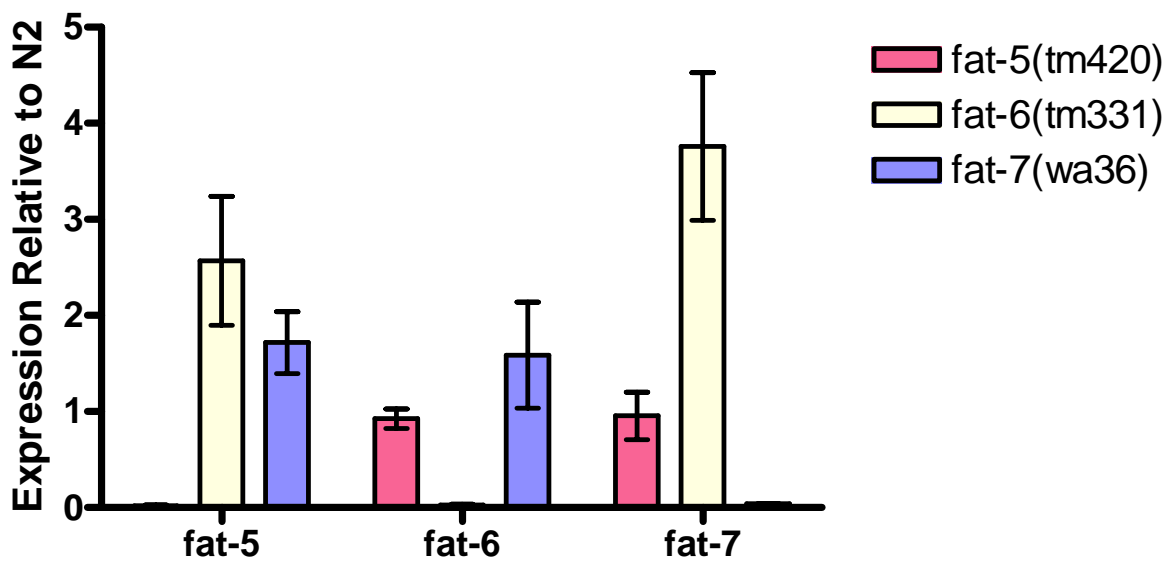


Figure 5. Expression of the $\Delta 9$ desaturase genes in the $\Delta 9$ desaturase mutants. Gene expression by RT-QPCR in the *fat-5*, *fat-6*, and *fat-7* mutants relative to N2 wild-type. Error bars represent standard error of 7-12 experiments.

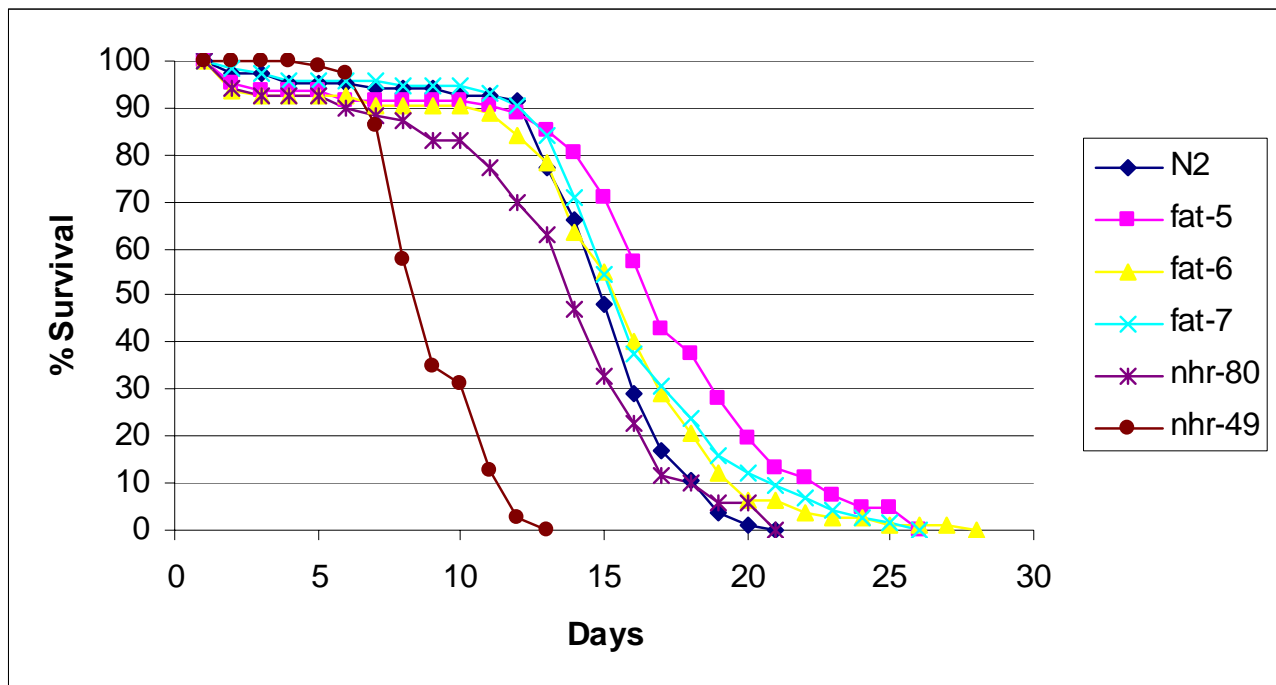


Figure 6. Aging of adult mutant populations. Life span of *nhr-49*, *nhr-80*, *fat-5*, *fat-6*, *fat-7* and N2 wild-type at 25°C. Data reported as mean lifespan +/- standard error (total number of animals scored). *nhr-49*: 8.2 +/- 0.2 (80); *nhr-80*: 12.5 +/- 0.5 (70); *fat-5*: 15.9 +/- 0.6 (82); *fat-6*: 14.2 +/- 0.5 (82); *fat-7*: 15.0 +/- 0.5 (75); N2: 13.9 +/- 0.4 (83).

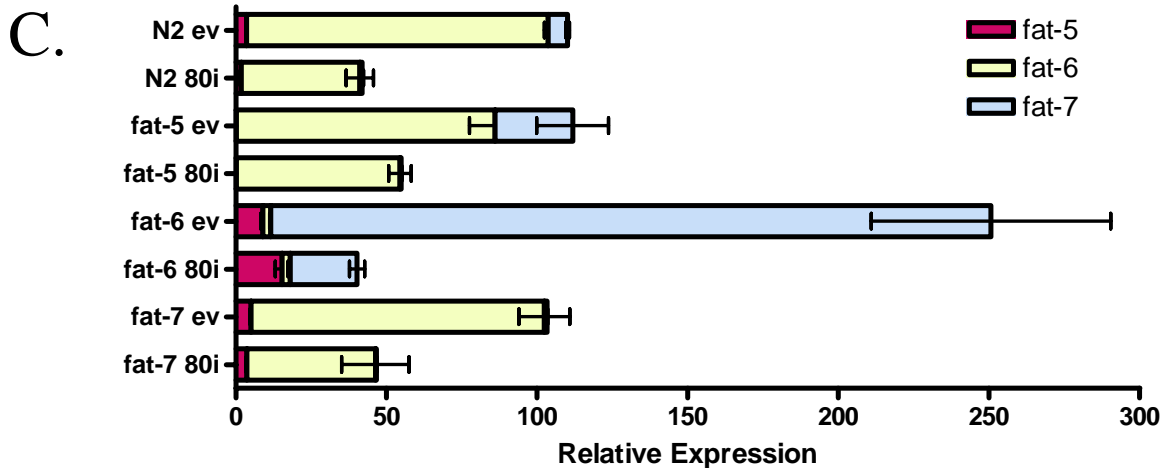
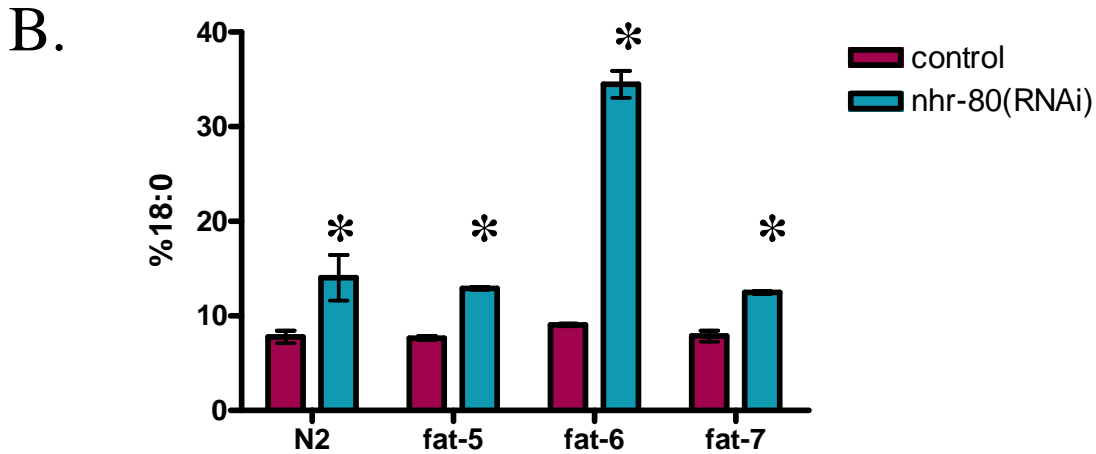
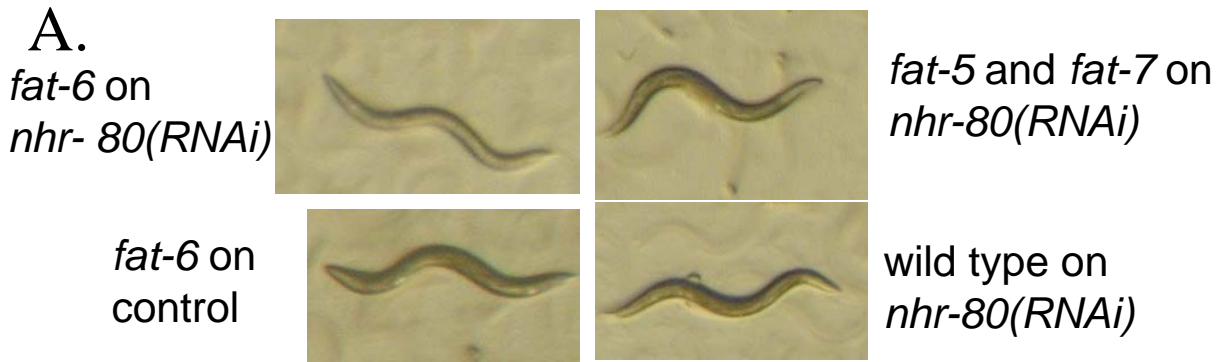


Figure 7. Effects of *nhr-80(RNAi)* in the $\Delta 9$ desaturase mutant background. **A.** Photographs showing adult worms after 4 days of growth on *nhr-80(RNAi)* and empty vector control bacteria. **B.** Relative abundance of 18:0 expressed as a percentage of total fatty acid as determined by GC analysis. The asterisk indicate a significant difference from growth on control bacteria with a P value <0.01. **C.** RT-QPCR in *fat-5*, *fat-6*, *fat-7*, and N2 wild-type for worms grown on empty vector control bacteria and *nhr-80(RNAi)*. Values are expressed relative to *fat-6* expression in N2 on control bacteria. For all graphs error bars represent standard error.

CHAPTER THREE

CHARACTERIZATION OF THE ROLE FOR FAT-5 AND FAT-6 IN STRESS SURVIVAL

Abstract

For an organism to survive it must respond and adapt to changing environmental conditions. Two of these common conditions are low temperature and starvation. We have found a role for the *C. elegans* $\Delta 9$ desaturases FAT-5 and FAT-6 in survival under these stressful conditions. To further examine the roles of the $\Delta 9$ fatty acid desaturases and the effects of altered fatty acid phenotypes we generated the *fat-5;fat-6* and *fat-5;fat-7* double mutants. The *fat-5;fat-7* double mutant has a very similar phenotype to the *fat-5* single mutant. However, the *fat-5;fat-6* double mutants while indistinguishable from wild-type under standard growth conditions showed a dramatic reduction in their ability to survive stress conditions. This reduction in stress survival is linked to an alteration in fatty acid composition. Wild-type animals are capable of growth and development at low temperatures and at those temperatures show decreased saturated fatty acid (SFA) accumulation and increased monounsaturated fatty acid (MUFA) accumulation. The *fat-5;fat-6* double mutants do not show this shift in fatty acid composition and have reduced survival at low temperatures. Another stress condition is starvation and wild-type animals have the ability to survive starvation for about six days. In contrast the *fat-5;fat-6* double mutants can only survive for about two days. The wild-type animals show little change in their fatty acid composition but the *fat-5;fat-6* double mutants are composed of more SFAs and less MUFAs when they are starved. Thus we see a requirement for *fat-5* or *fat-6* in surviving stress conditions.

Introduction

The $\Delta 9$ fatty acid desaturases are enzymes that catalyze the introduction of a double bond in a saturated fatty acid (SFA), creating a monounsaturated fatty acid (MUFA). The MUFAs produced are essential components of lipids such as membrane phospholipids and triglycerides. Thus the $\Delta 9$ desaturases play a vital role in maintaining membrane fluidity and energy storage, and have been isolated from many organisms. There is a high level of sequence identity in the $\Delta 9$ desaturases between organisms especially in the histidine-rich regions that coordinate the iron molecules at the active site (Watts and Browse, 2000).

Some organisms, including yeast (Stukey et al., 1989), pigs (Ren et al., 2004), and sheep (Ward et al., 1998), have only one $\Delta 9$ desaturase while others such as mice (Miyazaki et al., 2003), humans (Wang et al., 2005), and *C. elegans* (Watts and Browse, 2000), have multiple $\Delta 9$ desaturases. Although the exact reason for multiple $\Delta 9$ desaturases is not known, it is believed that the isozymes may each have unique roles. An example of this is seen in mice, an animal with four $\Delta 9$ desaturases called SCD1-4. Mice with mutations in *SCD1* are viable but the adults are low in fat and have increased energy expenditure (Ntambi et al., 2002). However, mice with mutations in *SCD2* have reduced survival and serious defects in skin and liver development (Miyazaki et al., 2005). Thus it is suggested that SCD1 is involved in adult fatty acid metabolism while SCD2 is involved in fatty acid metabolism in the developing embryo (Miyazaki et al., 2005). Roles for the other $\Delta 9$ desaturases, SCD3 and SCD4, have not been assigned.

C. elegans has three $\Delta 9$ desaturases (FAT-5, FAT-6, and FAT-7) making this a good model to study the different roles for these enzymes. One major advantage of using

C. elegans is that it is easy to manipulate genetically. *C. elegans* is typically hermaphroditic, but males do arise at a low frequency, allowing for ease in crossing between lines to generate double and triple mutants. The $\Delta 9$ desaturase single mutants showed little difference from wild-type worms (Chapter 2). Each of these mutants still has two $\Delta 9$ desaturases remaining. Double mutant combinations will allow us to examine the roles of the individual $\Delta 9$ desaturases.

All organisms will likely deal with many changes in environmental conditions in their lifespan and they must have the ability to respond to their changing environment. One condition is temperature and a common response to a change in temperature in poikilotherms is a change in fatty acid composition, with an increase in unsaturated fatty acids (Cossins et al., 2002). Fatty acids are an essential component of membrane phospholipids and at low temperatures an increase in unsaturated fatty acids helps keep membranes fluid and functioning. To achieve these changes in fatty acid composition the expression of $\Delta 9$ desaturases is induced (Gracey et al., 2004) indicating a role for $\Delta 9$ desaturases in surviving low temperatures.

Another changing environmental condition is the availability of food. Important for surviving these conditions is the ability to precisely regulate energy consumption and energy storage. Like mammals, *C. elegans* mobilizes the fat from fat stores to fulfill energy requirements during periods of starvation (McKay et al., 2003). This regulation of energy usage may be transcriptionally controlled in part by the nuclear hormone receptor NHR-49 (Van Gilst et al., 2005). The $\Delta 9$ desaturases also may play an important role in survival during starvation conditions. The fatty acid composition of *C. elegans* changes after removal from food, with an increase in the 18:0 SFA and a

decrease in the 16:0 SFA, and the MUFAs (Van Gilst et al., 2005). Twelve hours after removal from food the $\Delta 9$ desaturases FAT-5 and FAT-6 are upregulated in animals only in the first larval stage of development (L1), while the $\Delta 9$ desaturase FAT-7 is repressed at all life stages after fasting (Van Gilst et al., 2005).

Stress tolerance and fat metabolism have been linked in *C. elegans* in the *daf-2* mutants. These animals have an increased lifespan, increased stress tolerance, and increased fat storage (Kimura et al., 1997). DAF-2 is an insulin/IGF-1 receptor that activates a conserved PI-3 kinase pathway (Hertweck et al., 2004). Activation of DAF-2 signaling inhibits nuclear localization of DAF-16, a FOXO family transcription factor, and mutations in *daf-16* suppress the increased fat storage and stress tolerance in the *daf-2* mutants (Lin et al., 1997). The $\Delta 9$ desaturases are potential targets for DAF-16 transcriptional activation as these genes are induced in *daf-2* mutants but repressed in *daf-16;daf-2* double mutants (Murphy et al., 2003). As targets of DAF-16, the $\Delta 9$ desaturases and the fatty acids they produce may also play a role in fat storage and stress tolerance in *C. elegans*.

We have used mutant analysis to determine the roles for the $\Delta 9$ desaturases and MUFAs in *C. elegans*. The single mutants showed little difference from wild-type (Chapter 2) so we made double mutant combinations to further disrupt fatty acid desaturation. Despite slight changes in fatty acid composition the *fat-5;fat-6* and *fat-5;fat-7* double mutants are indistinguishable from wild-type under standard growth conditions. However, we find that *fat-5;fat-6* double mutant is sensitive to stress conditions, having reduced survival during conditions of low temperature and starvation.

Results and Discussion

The *fat-5;fat-6* and *fat-5;fat-7* double mutants under standard growth conditions.

To generate a *fat-5;fat-6* double mutant we crossed *fat-6(tm331)* males with *fat-5(tm420)* hermaphrodites. Mutant lines were selected by single worm PCR (SWPCR). The mutant allele amplicons are smaller than wild-type allele amplicons and easily detected on an agarose gel because both mutations are large deletions (Chapter 2). These double mutants rely on *fat-7* as their sole $\Delta 9$ desaturase, but show no obvious differences from wild-type under standard growth conditions. For example, at 25°C the average lifespan of the *fat-5;fat-6* double mutant is 15.5 \pm 0.5 days compared to the wild-type lifespan averaging 14.6 \pm 0.5 days (Figure 1A). In addition, their level of fat storage, as measured with the lipophilic dye Nile red, appears normal (Figure 1B). Nile red stains lipid droplets in the intestines of *C. elegans*. Wild-type animals show the same level of staining as *fat-5;fat-6* double mutants. So it appears that the $\Delta 9$ desaturation provided by FAT-7 is sufficient for growth and development under standard growth conditions.

The *fat-5;fat-6* double mutants do have a different fatty acid profile than wild-type (Figure 2A). They are elevated in SFA levels, the substrates for $\Delta 9$ desaturation, with these accounting for 15% of the total fatty acids in *fat-5;fat-6* compared with 12% in wild-type, and decreased in MUFAs, the products of $\Delta 9$ desaturation, with these accounting for 16% of the total fatty acids in *fat-5;fat-6* compared with 21% in wild-type. These differences aren't dramatic but they are significant with P values less than 0.01. However, the double mutant still does have a large fraction of MUFAs produced by FAT-7 and taken in from diet. The standard diet for *C. elegans* is OP50 *E. coli*, which contain SFAs such as 16:0 and 18:0 and MUFAs such as 16:1 $\Delta 9$ and 18:1 $\Delta 11$. These *E. coli* do

not contain the MUFA 18:1 Δ 9 or any PUFAs. The *fat-5;fat-6* double mutants must be able to meet their MUFA requirement with 16:1 Δ 9 and 18:1 Δ 11 from *E. coli* and 18:1 Δ 9 produce by FAT-7

To generate a *fat-5;fat-7* double mutant we crossed *fat-5(tm420)* males with *fat-7(wa36)* hermaphrodites. The *fat-5(tm420)* alleles were selected by SWPCR as the *fat-5* mutant amplicon is smaller than wild-type amplicon due to the large deletion (Chapter 2). The *fat-7(wa36)* allele was more difficult to detect. This mutation is a single base pair change (Chapter 2) so we developed a real-time SWPCR protocol to identify this allele. After lysis of the single worm the sample was divided for real-time PCR using two different primers. These PCR primers were designed to amplify either the mutant or wild-type *fat-7* allele when used with an in common reverse primer. In addition to the specificity in the 3' nucleotide of the primer (the 19th nucleotide), these primers also contained a mismatch at the 3rd nucleotide from the end (the 17th nucleotide) (Drenkard et al., 2000). The reactions were monitored in real-time to determine which product amplified faster. Using this protocol we generated the *fat-5;fat-7* double mutants, which rely on *fat-6* as their sole Δ 9 desaturase. Like the *fat-5;fat-6* double mutants, *fat-5;fat-7* double mutants show no obvious differences from wild-type under standard growth conditions. For instance, Nile red staining of fat accumulation in the *fat-5;fat-7* double mutants revealed no difference from wild-type (Figure 1B). The fatty acid profiles of these worms are slightly different than wild-type fatty acid profiles (Figure 2A). While the total fraction of SFAs is not significantly different from wild-type the total fraction of MUFAs is. The difference is seen predominantly in the level of 18:1 Δ 11, the elongation

product of 16:1 Δ 9, which is reduced in the *fat-5;fat-7* double mutants and accounts for 12% of the total fatty acids as compared with 16% in the wild-type animals.

These experiments with the *fat-5;fat-6* and *fat-5;fat-7* double mutant combinations show that FAT-6 or FAT-7 alone is sufficient for survival under standard laboratory growth conditions. Like yeast or sheep it seems that only one Δ 9 desaturase is necessary for survival in *C. elegans*. This is in contrast with mice, where mutations in either *SCD1* or *SCD2* cause severe phenotypes. The standard laboratory growth conditions provide some SFA and MUFAs from the OP50 *E. coli* provided as a food source. This may explain why we don't see dramatic changes in fatty acid profiles under the standard laboratory growth conditions.

The *fat-5;fat-6* and *fat-5;fat-7* double mutants grown in axenic culture have large changes in fatty acid composition.

To avoid the contribution from the bacterial fatty acids we grew the double mutants in axenic culture medium (Houthoofd et al., 2002). Without a bacterial food source the *fat-5;fat-6* and *fat-5;fat-7* double mutants show dramatic differences from wild-type in their fatty acid composition with increased SFAs and decreased MUFAs (Figure 2B). Under these conditions the fatty acid profiles of wild-type animals contain 25% SFAs and 47% MUFAs, *fat-5;fat-6* double mutants contain 45% SFAs and 16% MUFAs, and *fat-5;fat-7* double mutants contain 33% SFAs and 33% MUFAs. The *fat-5;fat-7* double mutant fatty acid composition is almost identical to the *fat-5* single mutant composition in axenic culture, but the *fat-5;fat-6* double mutants show much more dramatic changes than either the *fat-5* or *fat-6* single mutants alone (Chapter 2). This is more evidence that FAT-7 does not play an important role in maintaining the correct fatty

acid composition under axenic growth conditions. Elimination of *fat-7* in the *fat-5* mutant background does not affect fatty acid composition. Also the *fat-5;fat-6* double mutants which rely on FAT-7 as the sole $\Delta 9$ desaturase accumulate high levels of SFAs and are dramatically reduced in MUFAs.

The *fat-5;fat-6* double mutants are sensitive to low temperatures.

As a poikilothermic animal, *C. elegans* is sensitive to environmental temperatures making it a good model for studying temperature effects on fatty acid metabolism. To see if the $\Delta 9$ desaturases play a role in survival at low temperatures, we grew the *fat-5;fat-6* and *fat-5;fat-7* double mutants at 20°C, 15°C, and 10°C on OP50 *E. coli*. While the *fat-5;fat-7* double mutant responded similarly to *fat-5* and wild-type (data not shown), the *fat-5;fat-6* double mutant showed a reduced survival at 10°C (Figure 3A) compared to wild-type animals. Wild-type animals had the same survival at all three temperatures but though the *fat-5;fat-6* double mutants had approximately 100% survival at 20°C and 15°C, they had only about 45% survival at 10°C. The fatty acid composition of wild-type animals grown at 10°C was different from those grown at 20°C (Figure 3B). The SFA content of wild-type worms grown at 20°C did not change but the MUFA content increased from 20% for worms grown at 20°C to 26% for worms grown at 10°C. The SFA content of *fat-5;fat-6* double mutants increased from 15% at 20°C to 17% at 10°C. While the MUFA content of wild-type worms increased the MUFA content of *fat-5;fat-6* mutants actually decreased slightly from 16% for worms grown at 20°C to 15% at 10°C.

C. elegans is a soil nematode and has ideal growth in the temperature range of 16-25°C (Hope, 1999). While wild-type nematodes do not grow ideally at 10°C they still survive and they have a significant increase in their accumulation of 18:1 Δ 11. It is

possible that this increase in MUFAs helps these animals survive this low temperature as the the survival of *fat-5;fat-6* double mutants who don't have an increase in 18:1 Δ 11 is reduced. In addition these experiments with the *fat-5;fat-6* double mutant show that while FAT-7 provides sufficient Δ 9 desaturation activity under standard growth conditions it is insufficient for survival at low temperatures.

The *fat-5;fat-6* double mutants are sensitive to starvation.

In response to starvation, animals activate complex regulatory networks to utilize the energy stored as fat (Van Gilst et al., 2005). To determine the role for the Δ 9 desaturases in starvation response we examined survival of *fat-5;fat-6* double mutants under starvation conditions. In their development from egg to adult *C. elegans* goes through 4 larval stages. Animals in the first larval stage (L1) will arrest when faced with starvation conditions. When food is reintroduced development proceeds as normal (Hope, 1999). Wild-type nematodes and the *fat-5* and *fat-6* single mutants begin to die after 6 days of starvation as L1s, while the *fat-5;fat-6* double mutants begin to die after only 2 days (Figure 4A). Under these starvation conditions the fatty acid profiles of wild-type L1 stage animals don't change dramatically. While well-fed L1s have a fatty acid composition consisting of 14% SFAs and 22% MUFAs, the starved L1s have a fatty acid composition consisting of 16% SFAs and are unchanged in their percent MUFA composition. However, the fatty acid profile of the *fat-5;fat-6* L1s is dramatically affected by starvation (Figure 4B). When these double mutants are starved, their SFA composition rises from 17% in well-fed animals to 25% in starved animals, largely due to an increase in 18:0. Their MUFA composition drops from 25% in well-fed animals to 15% in starved animals with decreases seen in all three of the MUFAs.

L1 starved worms seem to be dependent on FAT-5 or FAT-6 for survival. These genes are upregulated in L1s as early as twelve hours after removal from food (Van Gilst et al., 2005). While FAT-7 can compensate for the lack of FAT-5 and FAT-6 under standard conditions, it appears that FAT-7 alone does not provide the level of desaturation needed for survival under stress conditions such as starvation and low temperature. Whether this is due to a down-regulation of *fat-7* under these conditions or an increased demand for MUFAs is not yet clear, but during starvation *fat-7* expression does decrease (Van Gilst et al., 2005).

Materials and Methods

Culture of nematodes

Unless otherwise noted, animals were grown according to standard methods with OP50 *E. coli* as a food source on NGM plates (Wood, 1988). The axenic culture media consisted of 3% soy peptone, 3% yeast extract, 0.5 mg/ml hemoglobin in 1M KOH, and 20% ultra-high temperature pasteurized skim milk (Houthoofd et al., 2002).

Genotyping of *fat-5(tm420)*, *fat-6(tm331)*, and *fat-7(wa36)*

Single worm PCR (SWPCR) (Wicks et al., 2001) was used to determine the genotype of worms during crossing to generate *fat-5;fat-6* and *fat-5;fat-7* double mutant lines. Males and hermaphrodites were allowed to mate. The F1 generation was isolated and allowed to reproduce. Once the F2 generation had progeny the F2 adults were picked into worm lysis buffer (50 mM KCl, 10 mM Tris-HCl pH 8.3, 2.5 mM MgCl₂, 0.45% NP-40, 0.45% Tween 20, 0.01% gelatine, freshly added 60 µg/ml proteinase K) for SWPCR analysis. The worms in lysis buffer were frozen at -80°C for at least 10 minutes then heated to 60°C for 60 minutes to digest the worms. The proteinase K was inactivated by heating to 95°C for 20 minutes. For *fat-5(tm420)* and *fat-6(tm331)* identification a PCR mix (2.2 µl 10xPCR buffer, 0.44 µl of 10 µM dNTP, 0.88 µl of each 10 µM primer stock, 1 µl 60% sucrose, 1 µl 0.1% cresol red, 0.22 µl Takara Ex-Taq polymerase, and water to 20 µl) was then added to each reaction and *fat-5* and *fat-6* were amplified in a standard PCR reaction using an MJ Research PTC-200 thermal cycler. Amplified products were run on a 0.8% agarose gel. For *fat-7(wa36)* identification real-time PCR was used. After lysis the sample was divided in two and a mix of 0.3 µM primers, ROX, and 1x SYBR green mix (Invitrogen Platinum SYBR green qPCR Supermix UDG) was added to each

half. One primer set was designed to be more active on the wild-type allele and one primer set was more active on the *fat-7(wa36)* mutation (Drenkard et al., 2000). The RT-PCR was run and monitored on a MX3000P (Stratagene). C_T 's and amplification curves were used to determine which amplification started first.

Phenotypic analysis

Lifespan analysis. Aging experiments were performed on adult nematodes grown at 25°C. Worms were moved to plates containing 5-fluoro-2'-deoxyuridine (Sigma) at the fourth larval stage of development (L4). Live animals were assayed for movement in response to touch every 1-2 days (Apfeld and Kenyon, 1998).

Nile red analysis. Nile red was added to seeded plates for a final concentration of 0.05 µg/ml and allowed to dry overnight. Nematode eggs were added to the plates and allowed to develop to adulthood. Adults were visualized by fluorescence microscopy on an Olympus IX70 microscope. Images were captured using a Nikon Coolpix 990 digital camera with identical settings and exposure time for each image.

Fatty acid composition. Adult nematodes were prepared for fatty acid composition analysis as described (Watts and Browse, 2002). Determination of fatty acid composition was performed by gas chromatography on an SP-2380 fused silica capillary column (Supelco) using an Agilent 6890 series GC

Cold temperature growth. Equal numbers of synchronous L1 worms were placed on plates at 20°C, 15°C, and 10°C. The number of live non-arrested worms was counted on each plate when the wild-type population reached adulthood. Numbers are expressed relative to the number of live non-arrested worms counted at 20°C.

L1 starvation survival. Embryos were collected from adult worms by hypochlorite treatment and hatched on unseeded NGM plates without peptone. This produced a population of *C. elegans* arrested in the first larval stage. These larvae were washed from the plate and incubated at room temperature in M9 buffer with cholesterol (10 µg/ml). Every 48 hours aliquots were transferred to standard NGM plates seeded with *E. coli* OP50 bacteria. After 3 days of growth at 20°C adult nematodes were counted (Derry et al., 2001).

References

- Apfeld, J., and Kenyon, C. (1998). Cell nonautonomy of *C. elegans* daf-2 function in the regulation of diapause and life span. *Cell* 95, 199-210.
- Cossins, A. R., Murray, P. A., Gracey, A. Y., Logue, J., Polley, S., Caddick, M., Brooks, S., Postle, T., and Maclean, N. (2002). The role of desaturases in cold-induced lipid restructuring. *Biochem Soc Trans* 30, 1082-1086.
- Derry, W. B., Putzke, A. P., and Rothman, J. H. (2001). *Caenorhabditis elegans* p53: role in apoptosis, meiosis, and stress resistance. *Science* 294, 591-595.
- Drenkard, E., Richter, B. G., Rozen, S., Stutius, L. M., Angell, N. A., Mindrinos, M., Cho, R. J., Oefner, P. J., Davis, R. W., and Ausubel, F. M. (2000). A simple procedure for the analysis of single nucleotide polymorphisms facilitates map-based cloning in *Arabidopsis*. *Plant Physiol* 124, 1483-1492.
- Gracey, A. Y., Fraser, E. J., Li, W., Fang, Y., Taylor, R. R., Rogers, J., Brass, A., and Cossins, A. R. (2004). Coping with cold: An integrative, multitissue analysis of the transcriptome of a poikilothermic vertebrate. *Proc Natl Acad Sci U S A* 101, 16970-16975.
- Hertweck, M., Gobel, C., and Baumeister, R. (2004). *C. elegans* SGK-1 is the critical component in the Akt/PKB kinase complex to control stress response and life span. *Dev Cell* 6, 577-588.
- Hope, I. A. (1999). *C. elegans: A practical approach* (Oxford, Oxford University Press).
- Houthoofd, K., Braeckman, B. P., Lenaerts, I., Brys, K., De Vreese, A., Van Eygen, S., and Vanfleteren, J. R. (2002). Axenic growth up-regulates mass-specific metabolic rate, stress resistance, and extends life span in *Caenorhabditis elegans*. *Exp Gerontol* 37, 1371-1378.
- Kimura, K. D., Tissenbaum, H. A., Liu, Y., and Ruvkun, G. (1997). daf-2, an insulin receptor-like gene that regulates longevity and diapause in *Caenorhabditis elegans*. *Science* 277, 942-946.
- Lin, K., Dorman, J. B., Rodan, A., and Kenyon, C. (1997). daf-16: An HNF-3/forkhead family member that can function to double the life-span of *Caenorhabditis elegans*. *Science* 278, 1319-1322.
- McKay, R. M., McKay, J. P., Avery, L., and Graff, J. M. (2003). *C. elegans*: a model for exploring the genetics of fat storage. *Dev Cell* 4, 131-142.
- Miyazaki, M., Dobrzyn, A., Elias, P. M., and Ntambi, J. M. (2005). Stearoyl-CoA desaturase-2 gene expression is required for lipid synthesis during early skin and liver development. *Proc Natl Acad Sci U S A* 102, 12501-12506.

Miyazaki, M., Jacobson, M. J., Man, W. C., Cohen, P., Asilmaz, E., Friedman, J. M., and Ntambi, J. M. (2003). Identification and characterization of murine SCD4, a novel heart-specific stearoyl-CoA desaturase isoform regulated by leptin and dietary factors. *J Biol Chem* 278, 33904-33911.

Murphy, C. T., McCarroll, S. A., Bargmann, C. I., Fraser, A., Kamath, R. S., Ahringer, J., Li, H., and Kenyon, C. (2003). Genes that act downstream of DAF-16 to influence the lifespan of *Caenorhabditis elegans*. *Nature* 424, 277-283.

Ntambi, J. M., Miyazaki, M., Stoehr, J. P., Lan, H., Kendziorski, C. M., Yandell, B. S., Song, Y., Cohen, P., Friedman, J. M., and Attie, A. D. (2002). Loss of stearoyl-CoA desaturase-1 function protects mice against adiposity. *Proc Natl Acad Sci U S A* 99, 11482-11486.

Ren, J., Knorr, C., Huang, L., and Brenig, B. (2004). Isolation and molecular characterization of the porcine stearoyl-CoA desaturase gene. *Gene* 340, 19-30.

Stukey, J. E., McDonough, V. M., and Martin, C. E. (1989). Isolation and characterization of OLE1, a gene affecting fatty acid desaturation from *Saccharomyces cerevisiae*. *J Biol Chem* 264, 16537-16544.

Van Gilst, M. R., Hadjivassiliou, H., and Yamamoto, K. R. (2005). From The Cover: A *Caenorhabditis elegans* nutrient response system partially dependent on nuclear receptor NHR-49. *Proc Natl Acad Sci U S A* 102, 13496-13501.

Wang, J., Yu, L., Schmidt, R. E., Su, C., Huang, X., Gould, K., and Cao, G. (2005). Characterization of HSCD5, a novel human stearoyl-CoA desaturase unique to primates. *Biochem Biophys Res Commun* 332, 735-742.

Ward, R. J., Travers, M. T., Richards, S. E., Vernon, R. G., Salter, A. M., Buttery, P. J., and Barber, M. C. (1998). Stearoyl-CoA desaturase mRNA is transcribed from a single gene in the ovine genome. *Biochim Biophys Acta* 1391, 145-156.

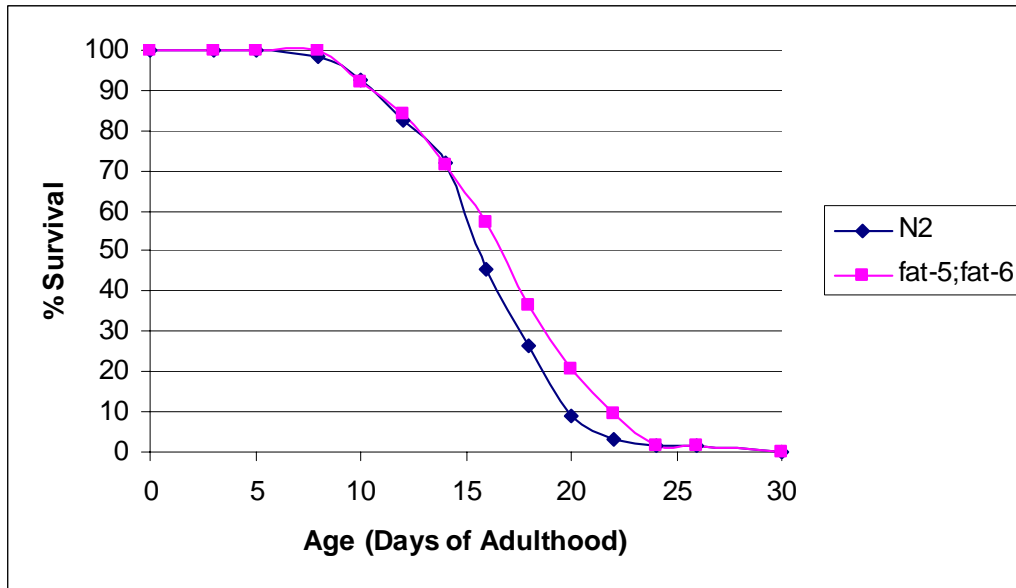
Watts, J. L., and Browse, J. (2000). A palmitoyl-CoA-specific delta9 fatty acid desaturase from *Caenorhabditis elegans*. *Biochem Biophys Res Commun* 272, 263-269.

Watts, J. L., and Browse, J. (2002). Genetic dissection of polyunsaturated fatty acid synthesis in *Caenorhabditis elegans*. *Proc Natl Acad Sci U S A* 99, 5854-5859.

Wicks, S. R., Yeh, R. T., Gish, W. R., Waterston, R. H., and Plasterk, R. H. (2001). Rapid gene mapping in *Caenorhabditis elegans* using a high density polymorphism map. *Nat Genet* 28, 160-164.

Wood, W. B. (1988). *The Nematode Caenorhabditis elegans* (Cold Spring Harbor, NY, Cold Spring Harbor Laboratory Press).

A.



B.

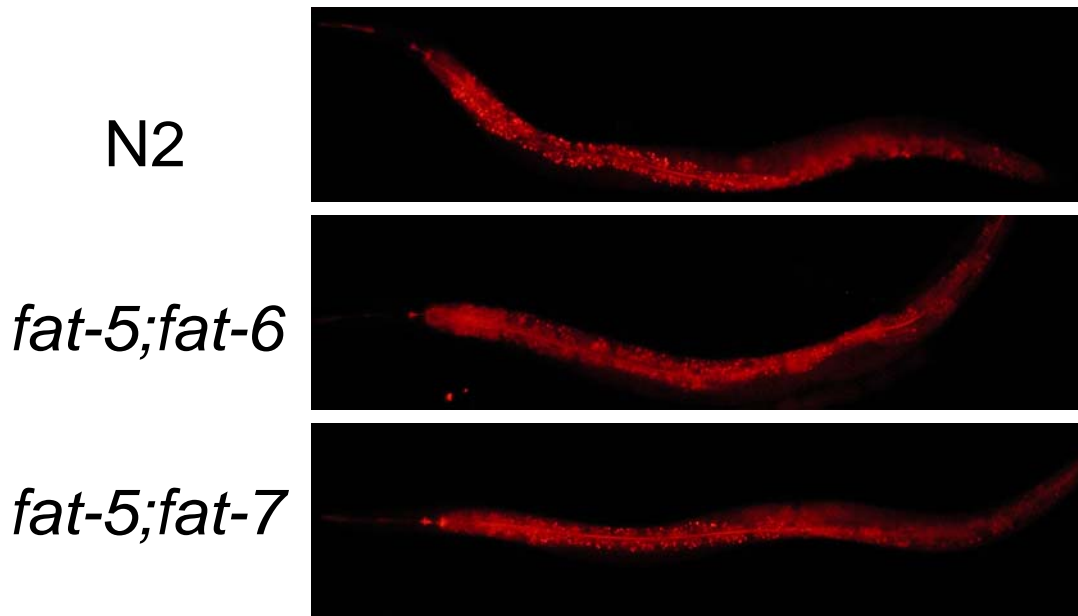


Figure 1. The *fat-5;fat-6* double mutants are indistinguishable from wild-type under standard growth conditions. **A.** Aging of adult *fat-5;fat-6* compared to N2 wild-type. Data reported as mean lifespan +/- standard error (total number of animals scored). *fat-5;fat-6*: 15.5 +/- 0.5 (63), N2 14.6 +/- 0.5 (68). **B.** Typical Nile red staining of the intestine of adult *fat-5;fat-6*, *fat-5;fat-7* and N2 wild-type. 10X amplification.

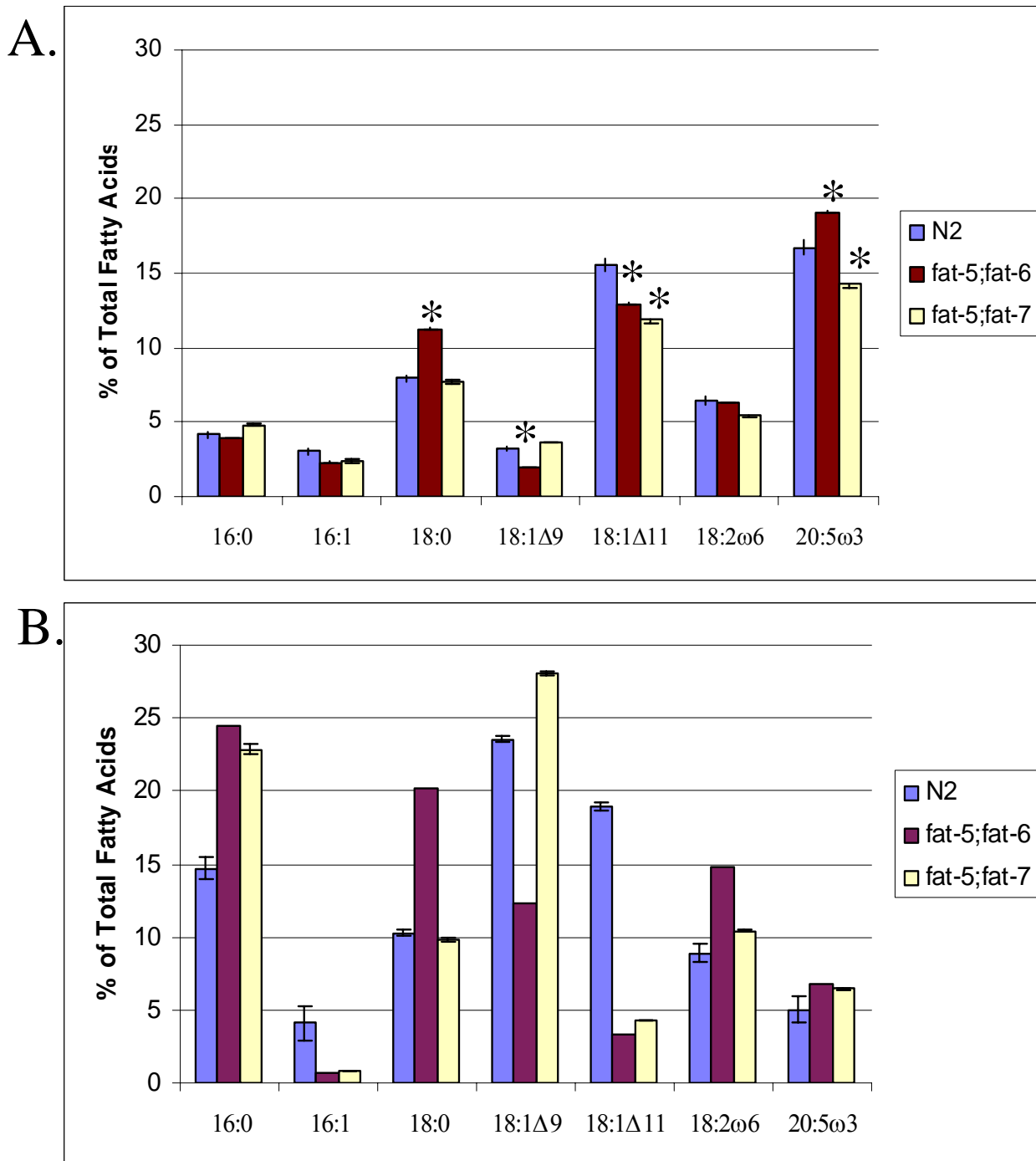


Figure 2. Fatty acid composition of the $\Delta 9$ desaturase double mutants. **A.** Standard growth conditions for *fat-5;fat-6*, *fat-5;fat-7* and N2 wild-type. Asterisk indicate a significant difference from wild-type with P values <0.01 **B.** Axenic growth conditions for *fat-5;fat-6*, *fat-5;fat-7* and N2 wild-type. In both graphs relative abundance of selected fatty acid species is expressed as percentage of total fatty acid as determined by GC analysis. Error bars represent the standard error.

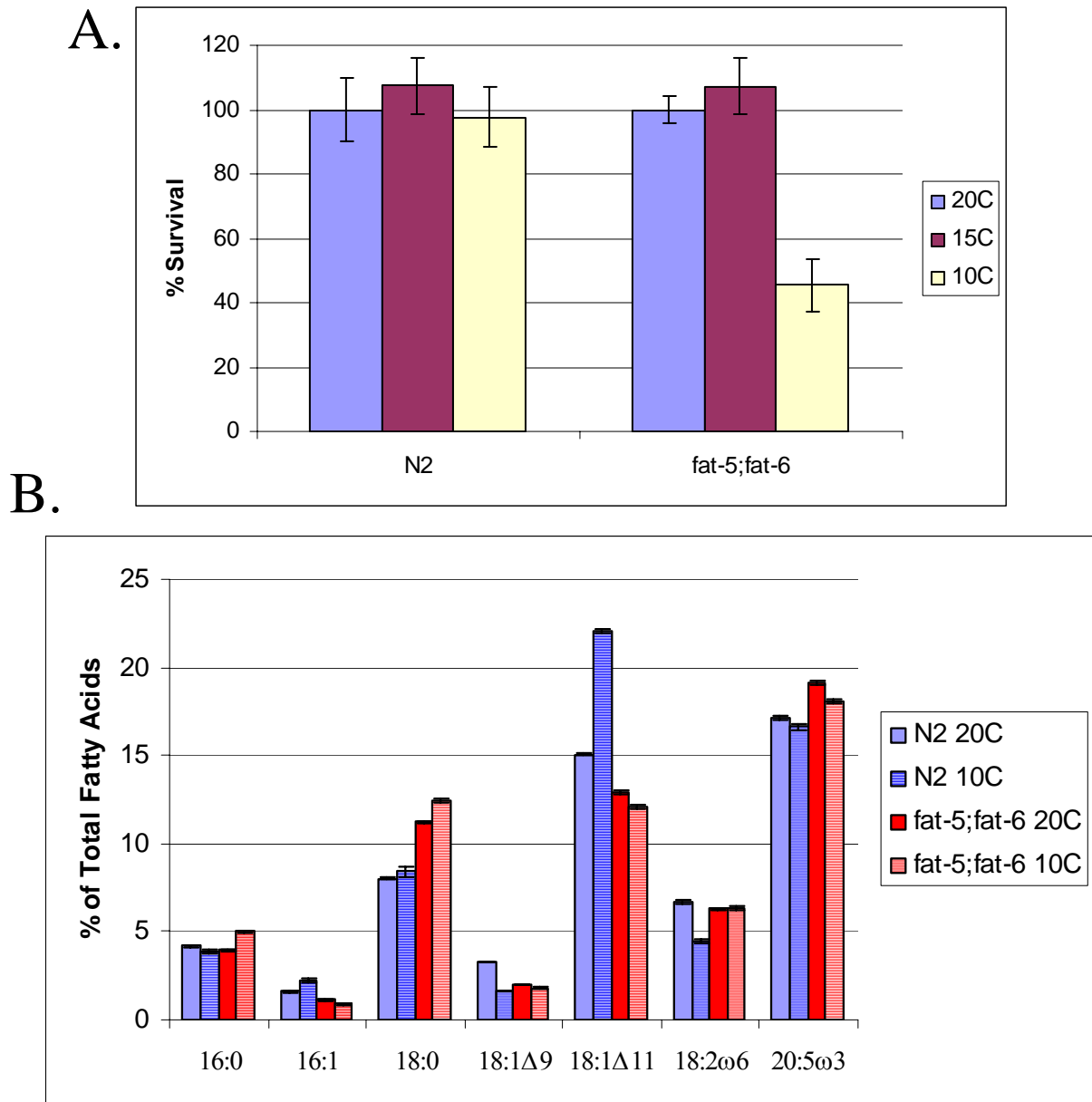
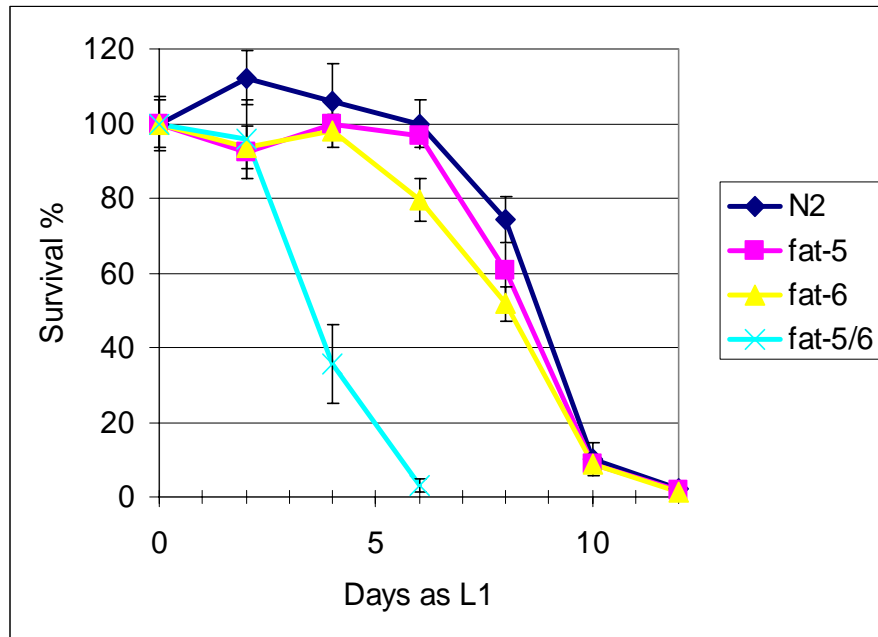


Figure 3. Cold sensitivity in the *fat-5;fat-6* double mutants. **A.** Survival at 15°C and 10°C relative to that at 20°C for *fat-5;fat-6* and N2 wild-type. **B.** Fatty acid composition of worms grown at 20°C and 10°C. Relative abundance of selected fatty acid species is expressed as percentage of total fatty acid as determined by GC analysis. Error bars represent the standard error.

A.



B.

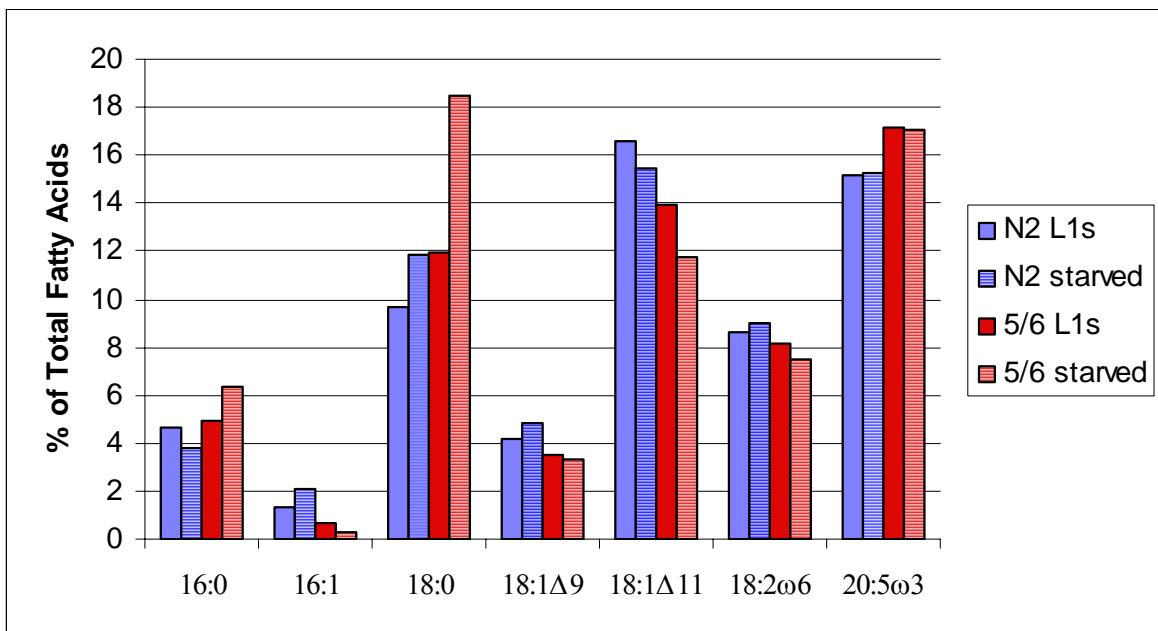


Figure 4. Starvation sensitivity in the *fat-5;fat-6* double mutants. **A.** Survival as L1s for *fat-5*, *fat-6*, *fat-5;fat-6*, and N2 wild-type. Error bars represent the standard error. **B.** Fatty acid composition of L1 worms that are well-fed compared to starved L1 worms. Relative abundance of selected fatty acid species is expressed as percentage of total fatty acid as determined by GC analysis.

CHAPTER FOUR
CHARACTERIZATION OF THE ROLE OF FAT-6
AND FAT-7 IN ENERGY METABOLISM

Abstract

Throughout the world the incidence of obesity is increasing, highlighting the need for a greater understanding of energy metabolism. In mammals, one of the key players in energy metabolism is the $\Delta 9$ desaturase SCD1. The increased expression of this desaturase contributes significantly to the increase in body fat in leptin mutant mice, and SCD1 knockout mice are low in fat and resistant to weight gain. We have characterized the *fat-6;fat-7* double mutant in *C. elegans*. These double mutants produce no 18:1 $\Delta 9$ and none of the normal 20-carbon PUFAs because 18:1 $\Delta 9$ is a precursor for their synthesis. However, we have identified some unusual PUFAs produced by the *fat-6;fat-7* double mutants. The *fat-6;fat-7* double mutants display growth and development phenotypes that can be complemented biochemically with dietary fatty acid supplementation. Like SCD1 mutants, *fat-6;fat-7* double mutants are also reduced in fat storage. Examination of gene expression in these double mutants has revealed a dramatic increase in the expression of genes involved in fatty acid β -oxidation. This indicates that the decrease in fat storage in the *fat-6;fat-7* double mutant may be due to an increase in β -oxidation. Viable mutants with reduced fat stores have not yet been described in *C. elegans* and the *fat-6;fat-7* double mutant may prove to be a valuable model for understanding energy metabolism because these $\Delta 9$ desaturases are central enzymes in the energy metabolism pathways.

Introduction

The incidence of obesity is increasing throughout the world, with severe consequences for human health. Increased body fat is associated with increased mortality and can also lead to other serious health conditions including diabetes and heart disease (Kopelman, 2000). Currently there are few effective therapeutic options for treatment of obesity and the available options often have serious side effects (Flier, 2004). This is in part due to our lack of understanding of the complicated issues involved in fat metabolism. Energy usage and fat storage is a delicate balance affected by environmental and genetic factors. A central enzyme in this balance is the $\Delta 9$ fatty acid desaturase. The $\Delta 9$ desaturase is under tight control and is down regulated by environmental conditions, such as dietary fat, and genetic factors, such as leptin expression.

Characterization of mice lacking the $\Delta 9$ desaturase SCD1, (ab^J/ab^J and $SCD1^{-/-}$ mice) has revealed a central role for this desaturase in fat metabolism and storage. Substrate specificity for SCD1 has been suggested by experiments revealing that the 16:0 to 16:1 $\Delta 9$ desaturation is unaffected while the 18:0 to 18:1 $\Delta 9$ desaturation is dramatically reduced in certain tissues in $SCD1^{-/-}$ mice (Miyazaki et al., 2001a). $SCD1^{-/-}$ mice have lower levels of triglycerides (TAG), the fat storage molecule, in liver and blood even when fed MUFAs in the diet (Miyazaki et al., 2000). In wild-type mice TAG production and SCD1 activity are induced in the liver upon feeding of a high carbohydrate diet; however, $SCD1^{-/-}$ mice on the same diet there exhibit no increase in TAG production in the liver, indicating that SCD1 activity is necessary for this production (Miyazaki et al., 2001b). Also $SCD1^{-/-}$ mice have lower body fat and are resistant to weight gain (Ntambi

et al., 2002). In these mutants, the expression of β -oxidation genes is increased and the mice have increased energy expenditure (Ntambi et al., 2002). Based on these experiments, SCD1 seems to play a critical role in the generation of body fat and is required for proper energy metabolism.

Leptin, a hormone produced by fat cells, is a key regulator of fat metabolism and SCD1 expression in mammals. Both mice and humans with leptin deficiency have increased body fat, and treatment with leptin reduces fat accumulation (Farooqi et al., 1999; Pelleymounter et al., 1995). Leptin is secreted into the blood stream by fat cells. It binds to leptin receptors found on many cell types including hypothalamus, liver, and muscle cells (Cohen et al., 2005; Tartaglia et al., 1995) and activates signal transduction pathways. Through these signaling pathways leptin mediates many processes including energy homeostasis, body weight, appetite, fat stores, insulin signaling, reproduction and development (Hegyí et al., 2004). One effect of leptin signaling is a decrease in SCD1 expression. SCD1 is upregulated 700% in leptin deficient mouse mutants (*ob/ob*) compared to wild-type (Ntambi et al., 2002). Mice lacking both leptin and SCD1 (*ob/ob; ab^J/ab^J*) have significantly lower fat than leptin single mutants (Ntambi et al., 2002). This indicates that part of the effect of leptin on body weight regulation may be due to a decrease SCD1 activity.

SCD1 may act in fat metabolism through the AMP-activated protein kinase (AMPK), a crucial enzyme in maintaining energy balance within a cell. Homologues of AMPK have been found in all eukaryotes examined including *C. elegans* and humans (Apfeld et al., 2004; Stapleton et al., 1997). AMPK is activated in response to depleted ATP stores and, upon activation, AMPK has many phosphorylation targets (Carling,

2004). The overall effect of these phosphorylation events is to promote ATP-generating pathways such as β -oxidation and limit ATP-consuming pathways such as fatty acid synthesis (Kemp et al., 1999). In mice lacking SCD1 (*SCD1*^{-/-}), β -oxidation pathways and energy expenditure are increased resulting in lower body fat (Ntambi et al., 2002). In these mutants AMPK has higher levels of activity than in control mice and the activated AMPK promotes β -oxidation (Dobrzyn et al., 2004). These results indicate that AMPK is a mediator of increased β -oxidation in the liver of *SCD1*^{-/-} mice.

C. elegans has three $\Delta 9$ desaturases involved in energy metabolism. FAT-6 and FAT-7 have a substrate specificity similar to mouse SCD1, as they are more active on 18:0 SFAs than 16:0 SFAs (Watts and Browse, 2000). The MUFA 18:1 $\Delta 9$ generated by these desaturases is the substrate for further desaturation and elongation steps to create polyunsaturated fatty acids (PUFAs) including arachidonic acid (20:4 $\omega 6$) and eicosapentaenoic acid (20:5 $\omega 3$) (Watts and Browse, 2002). These PUFAs are essential components of membrane phospholipids where they play important roles in maintaining membrane fluidity and function. In mammals, PUFAs can be oxygenated to form eicosanoids, signaling molecules involved in many physiological processes (Funk, 2001). Thus PUFAs are important for cell function in higher eukaryotes.

Mammals do not have $\Delta 12$ or $\omega 3$ desaturase activity and cannot synthesize PUFAs endogenously (Wallis et al., 2002). As a result they have a dietary requirement for the fatty acids 18:2 $\omega 6$ and 18:3 $\omega 3$. Enzymes, such as the $\Delta 5$ and $\Delta 6$ desaturases, metabolize these dietary fatty acids to produce the complex PUFAs required for mammalian growth and development. If the dietary fatty acid requirement is not met,

symptoms can include poor growth, scaly skin lesions, reduced body weight, and infertility (Heird and Lapillonne, 2005; Smit et al., 2004).

C. elegans does not have a dietary fatty acid requirement and has the desaturases necessary to synthesize the PUFAs required, such as 20:4 ω 6 and 20:5 ω 3 (Wallis et al., 2002). The FAT-2 enzyme is a Δ 12 desaturase not found in mammals. Worms with mutations in this desaturase are slow growing and moving and have abnormal body shape, cuticle defects, and reduced fertility (Watts and Browse, 2002). These worms have an accumulation of 18:1 Δ 9 and an absence of normal PUFAs. FAT-2 converts 18:1 Δ 9 to 18:2 ω 6 which is then substrate for further desaturation and elongation to make the 20-carbon PUFAs. FAT-3 is a Δ 6 that acts on 18:2 ω 6 and 18:3 ω 3, a step that is required before elongation of 18-carbon PUFAs to 20-carbon PUFAs. Mutations in *fat-3* lead to worms with neuromuscular defects, cuticle abnormalities, reduced fertility, and altered biological rhythms (Watts et al., 2003). These worms have reduced 20-carbon PUFAs and no Δ 6 fatty acids. Both of the *fat-2* and *fat-3* mutant phenotypes can be rescued by dietary supplementation of the fatty acids they lack.

We have used mutant analysis to determine the roles for the Δ 9 desaturases and MUFAs in *C. elegans*. Because single mutants showed little difference from wild-type (Chapter 2), we made double mutant combinations to further disrupt fatty acid desaturation. The *fat-6;fat-7* double mutants are viable and fertile, but have severe phenotypes including slow growth rate and reduced brood size. These phenotypes can be partially biochemically complemented by dietary supplementation. The double mutants cannot synthesize 18:1 Δ 9 and have none of the normal PUFAs found in wild-type

animals. They also have reduced fat stores and an increase in β -oxidation. These results show the importance of $\Delta 9$ desaturation in energy metabolism.

Results and Discussion

***fat-6;fat-7* have a severely altered fatty acid profile**

The *fat-6(tm331);fat-7(wa36)* mutant line was generated by crossing *fat-6* males with *fat-7* hermaphrodites and screened using single worm PCR (SWPCR). The *fat-6(tm331)* mutation is a deletion (Chapter 2) and was identified because of the small amplicon size. The *fat-7(wa36)* mutation is a single base pair change (Chapter 2) and was identified using real-time SWPCR (Chapter 3).

The three $\Delta 9$ desaturases of *C. elegans* have different substrate specificities. FAT-5 is most active on 16:0 SFA while FAT-6 and FAT-7 are most active on 18:0 SFA. Thus we predicted that the *fat-6;fat-7* double mutants would lack the $\Delta 9$ desaturation product of 18:0, which is 18:1 $\Delta 9$. Indeed this is what we saw when we examined the fatty acid composition of the *fat-6;fat-7* double mutants (Figure 1). These double mutants lacked 18:1 $\Delta 9$ and the PUFAs made using this as a substrate such as 18:2 $\omega 6$ and 20:5 $\omega 3$. However, they did produce some unusual fatty acids that we identified using GC/MS. Our typical determination of fatty acid composition is done using GC to separate and quantify the fatty acids present in our samples (Watts and Browse, 2002). The fatty acids are identified by their run time relative to known fatty acids. To identify unknown fatty acids we used GC/MS to determine the structure of the fatty acid (Watts and Browse, 1999). Each fatty acid has a unique mass spectrum which allows identification of the number of carbons, the number of double bonds and the positions of those double bonds. The *fat-6;fat-7* double mutants produced a 16:2($\Delta 9,12$), a 16:3($\Delta 6,9,12$), an 18:1 $\Delta 13$, an 18:3($\Delta 8,11,14$), an 18:4($\Delta 5,8,11,14$), and an 18:4($\Delta 8,11,14,17$) not typically found in wild-type *C. elegans*.

To see the effect of this dramatic change in fatty acid composition on gene expression we monitored expression of 180 genes involved in carbohydrate and fatty acid metabolism by quantitative PCR (QPCR) (Van Gilst et al., 2005). We found that the desaturase and elongase genes were dramatically upregulated. In fact, the genes for *fat-2*, *fat-3*, *fat-4*, *fat-5*, and *elo-2* all had increased expression in the *fat-6;fat-7* double mutants as compared to wild-type (Figure 2A). The biggest change in expression was seen in *fat-5*, which has 52-fold greater expression in the *fat-6;fat-7* double mutants than in wild-type animals. Expression of *fat-2* was also increased dramatically with 13-fold higher expression in the *fat-6;fat-7* double mutants. Also increased in the double mutants relative to wild-type are *fat-3* (3-fold), *fat-4* (2-fold), and *elo-2* (4-fold). The *fat-6;fat-7* double mutants may sense that they don't have the proper fatty acid composition and increase expression of the genes for the desaturases and elongases that make the fatty acids they lack. This also may explain why we see unusual desaturation and elongation products in the *fat-6;fat-7* double mutant. Using this information we have proposed a pathway for generation of the unusual fatty acids found in the *fat-6;fat-7* double mutants (Figure 2B). FAT-5 can desaturate short-chain SFAs such as 16:0 and 14:0 (Watts and Browse, 2000). We propose that in the *fat-6;fat-7* double mutant FAT-5 acts on 14:0 to generate 14:1 Δ 9. This is elongated twice to produce 18:1 Δ 13. In the *fat-6;fat-7* double mutants FAT-5 also acts on 16:0 to produce 16:1 Δ 9. 16:1 Δ 9 could then be desaturated by FAT-2 to 16:2(Δ 9,12), which could be a substrate for FAT-3 to generate 16:3(Δ 6,9,12). This could be elongated to 18:3(Δ 8,11,14), which could be the substrate for two different desaturases. The FAT-2 could act again on this fatty acid, as a $v+3$

(Sasata et al., 2004), generating 18:4(Δ 8,11,14,17), or the FAT-4, a Δ 5 desaturase (Watts and Browse, 1999), could act to generate 18:4(Δ 5,8,11,14).

***fat-6;fat-7* double mutants have a normal lifespan**

It has been suggested that shifts in the ratio of SFA to MUFA in *C. elegans* may lead to a decreased lifespan. This is seen in both the *nhr-49* (Van Gilst et al., 2005) and *wa3* (Appendix 1) mutants which have increased 18:0 accumulation and short lifespans. We examined the lifespan of the *fat-6;fat-7* double mutants and found that they showed no early death phenotype (Figure 3). The average lifespan of the *fat-6;fat-7* mutant at 20°C was 17.7 \pm 0.6 days as compared to 19.6 \pm 0.7 days in wild-type animals. The *fat-6;fat-7* double mutants had a slightly shorter lifespan than wild-type but difference is not significant based on a t test analysis and is certainly not as short as the early death seen in *nhr-80* and *wa3* mutants. The early death of the *nhr-49* and *wa3* mutants does not seem to be caused by an increase in 18:0 accumulation as *fat-6;fat-7* mutants also have high 18:0 (27% of the total fatty acids) and no shortened lifespan.

***fat-6;fat-7* double mutants have a reduced growth rate**

Upon generation of the *fat-6;fat-7* double mutant it was immediately apparent that these worms had a severe phenotype like other *C. elegans* desaturase mutants such as *fat-2* and *fat-3* (Watts and Browse, 2002). Unlike the *fat-2* and *fat-3* mutants, however, *fat-6;fat-7* double mutants were not dumpy and were capable of wild-type levels of movement. These unusual 16 and 18 carbon PUFAs synthesized by the *fat-6;fat-7* double mutants may explain the lack of movement and cuticle defects in these mutants (Table 1). The *fat-2*, *fat-3*, and *fat-6;fat-7* double mutants are all reduced in 20-carbon PUFAs but only the *fat-2* and *fat-3* mutants have movement and cuticle defects. We

characterized the slow growth rate of the *fat-6;fat-7* double mutants by analyzing the time from hatching to the fourth larval stage of development (L4). The *fat-6;fat-7* double mutants reached the L4 stage well after wild-type animals (Figure 4A). We calculated the time for half of the population to reach L4 ($L_{4_{50}}$) and found that it was 57 hours for wild-type and 83 hours for *fat-6;fat-7* double mutants. However, this slow growth could be complemented biochemically by dietary supplementation of the MUFA 18:1 Δ 9 or PUFAs including 20:5 ω 3, the final product in the desaturation pathway (Figure 4A). When *fat-6;fat-7* double mutant eggs were grown on supplemented plates they reached $L_{4_{50}}$ at 64 hours for 20:5 ω 3 supplementation and 68 hours for 18:1 Δ 9. This partial complementation could be explained by experimental considerations. The wild-type animals are starting from eggs with the proper fatty acid composition, while the supplemented *fat-6;fat-7* double mutants must get their fatty acids from the diet and this may explain the lag in their growth. We used GC analysis to determine the combined amount of 18:1 Δ 9, 18:2 ω 6, and 20-carbon PUFAs found in adults of each worm population. These fatty acids are not produced in the *fat-6;fat-7* double mutants but wild-type animals produce them at 22% of their total fatty acids. The 20:5 ω 3 supplemented *fat-6;fat-7* double mutants incorporate this dietary fatty acid to comprise 22% of their total fatty acids, while the *fat-6;fat-7* double mutants supplemented with 18:1 Δ 9 further elongate and desaturate this dietary fatty acid to generate 11% of their total fatty acids as a combination of 18:1 Δ 9, 18:2 ω 6, and 20-carbon PUFAs. We assayed a range of supplementation concentrations to examine the effects of different levels of 18:1 Δ 9, 18:2 ω 6, and 20-carbon PUFAs. The rescue of growth rate occurred in a dose-dependant

manner with increased levels of supplementation leading to increased growth rates (Figure 4B).

Other *C. elegans* mutant lines with severely reduced PUFA production, such as *fat-2* and *fat-3*, also display a severe phenotype of slow development. This is also similar to a symptom of essential fatty acid deficiency in humans (Heird and Lapillonne, 2005). These conditions can be rescued by dietary supplementation with PUFAs, but the mechanisms linking PUFAs and growth are not yet known (Smit et al., 2004). *C. elegans* may be a good model to study this connection as there is a requirement for PUFAs in *C. elegans* growth and development, and development is a well-studied process in *C. elegans*.

***fat-6;fat-7* double mutants have reduced fertility**

We observed an increase in the number of unhatched eggs on the *fat-6;fat-7* double mutant plates. To quantify this we counted the number of live progeny produced by a single animal and compared it to wild-type. We found that the *fat-6;fat-7* double mutants produce an average of 37 \pm 9 live progeny per adult worm while wild-type animals produce an average of 260 \pm 10 live progeny per adult worm (Figure 5A). The *fat-6;fat-7* double mutants produce fewer eggs overall than wild-type, 112 eggs compared to 311 eggs. In addition, many of the eggs produced by *fat-6;fat-7* double mutants fail to hatch. The rate of hatching in wild-type is 85% and the rate in *fat-6;fat-7* is 34%. The majority of unhatched eggs produced by the *fat-6;fat-7* double mutants have defective eggshells. This was seen by microscopic visualization of the unhatched eggs in which we observed gross abnormalities in eggshells or absent eggshells for 58% of the eggs.

We also examined whether the low fertility in the *fat-6;fat-7* double mutants could be rescued by dietary fatty acid supplementation. The MUFA 18:1 Δ 9 was capable of rescuing the fertility of the *fat-6;fat-7* double mutants but the PUFA 20:5 ω 3 was not (Figure 5B). Here instead of counting the total number of live progeny produced by a single animal we counted the number of progeny produced in two days. We see that supplementation of 18:1 Δ 9 in *fat-6;fat-7* double mutants increases their live progeny production from 20 \pm 4 live worms to 82 \pm 9 live worms. The fatty acids 18:1 Δ 9, 18:2 ω 6, and 20-carbon PUFAs made up only about 6% of the total fatty acids in these supplemented *fat-6;fat-7* double mutants compared with 22% in wild-type worms (155 \pm 2 live progeny). Supplementation with 20:5 ω 3 does not increase progeny production as the *fat-6;fat-7* double mutants grown under these conditions actually produce fewer (11 \pm 3) live worms. The level of 20:5 ω 3 from the diet in these *fat-6;fat-7* double mutants was 22% of the total fatty acids. The reduction in fertility is similar to that seen in the *fat-3* mutants but the *fat-6;fat-7* double mutant phenotype is more severe. The *fat-3* mutant can be rescued by 20:5 ω 3 (Watts et al., 2003) but these mutants also contain 18:1 Δ 9 and 18:2 ω 6 fatty acids that the *fat-6;fat-7* mutants do not produce. The biochemical complementation with 18:1 Δ 9 but not 20:5 ω 3 indicates a specific role for 18:1 Δ 9 or one of its desaturation or elongation products in reproduction.

***fat-6;fat-7* have reduced fat storage**

In addition to the decreased growth rate, reduced fertility and altered fatty acid profile, we also noticed that the *fat-6;fat-7* double mutants were paler than wild-type worms indicating reduced fat stores. To visualize this we used the lipophilic dye Nile red to stain the lipid droplets in the intestine (Figure 6A) (Ashrafi et al., 2003). This staining

in *fat-6;fat-7* mutants was much more diffuse than wild-type and we didn't see distinct lipid droplets. We quantified the staining and found that wild-type worms had an average fluorescence of 82 \pm 5 U compared with the average for *fat-6;fat-7* double mutants of 33 \pm 6 U (Figure 6B). To further quantify this decrease in fat storage we characterized the lipid profile of the *fat-6;fat-7* double mutants and found a decrease in TAG stores. The percent of lipids as TAG was 42% in wild-type animals and 28% in *fat-6;fat-7* double mutants, a difference that is significant ($P < 0.01$). As TAG is the fat storage molecule, this confirms the Nile red results showing a decrease in fat storage. The *fat-6;fat-7* is the first description of a viable low fat mutant in *C. elegans*. Several mutants with high fat have been characterized, such as those in the serotonin (Sze et al., 2000) and *tubby* (Mukhopadhyay et al., 2005) signaling pathways. The RNAi screen identified RNAi clones that caused a decrease in Nile red staining but none of those genes have yet been characterized in detail (Ashrafi et al., 2003). In addition, other RNAi clones that caused low fat also resulted in larval arrest of the low fat animals (McKay et al., 2003). A viable low fat mutant, like the *fat-6;fat-7* double mutant, is a valuable tool for studying energy metabolism pathways.

We analyzed the fatty acid composition of the different lipid classes (Figure 7). All of the classes have much higher accumulation of SFA in the *fat-6;fat-7* double mutants, for instance in the wild-type TAG there is 7% SFA and in the *fat-6;fat-7* double mutant there is 30%. Also all of the lipids have lower levels of 20-carbon PUFAs, as seen in the phosphatidyl choline (PC) where wild-type have 44% 20-carbon PUFAs compared with 3% in the *fat-6;fat-7* double mutants. The unusual 16- and 18-carbon PUFAs found in the *fat-6;fat-7* double mutants are most abundant in the PC accounting

for 26% of the total fatty acids. We see the effect of the loss of 20-carbon PUFAs in the *fat-6;fat-7* double mutants in the phospholipids. The TAG instead shows the dramatic increase in SFA.

***fat-6;fat-7* have an increase in β -oxidation**

In our characterization of the expression of metabolism genes in *fat-6;fat-7* we also found a dramatic increase in the expression of genes involved in the β -oxidation pathway. We found increased expression for genes representing every step of the β -oxidation pathway (Figure 8). This could indicate that the reduced fat storage is due to an increase in β -oxidation. This is in contrast to characterization of the gene expression in *nhr-49* mutants. Those mutants have increased fat storage and decreased expression of the β -oxidation genes *acs-2* and *ech-1* (Van Gilst et al., 2005). ACS-2 is an acyl-CoA synthetase gene, and ECH-1 is an enoyl-CoA hydratase. Using RNAi to reduce expression of these genes showed an increase in Nile red staining which indicated that the high fat in *nhr-49* mutants was due to the decrease in the β -oxidation genes *acs-2* and *ech-1*.

These genes were increased in expression in the *fat-6;fat-7* double mutants compared to wild-type. We hypothesized that the decrease in fat storage in the *fat-6;fat-7* double mutants might be due to an increase in β -oxidation. To test this we used RNAi to knock-down expression of the β -oxidation genes *acs-2* and *ech-1* and saw how fat storage as measured by Nile red staining was affected. We found that *acs-2(RNAi)* had no effect on Nile red staining, but *ech-1(RNAi)* increased staining in *fat-6;fat-7* double mutants (Figure 6A and B). In *fat-6;fat-7* double mutants Nile red staining was increased from 33 U in both empty vector control and *acs-2(RNAi)* grown worms to 62 \pm 6 U in

ech-1(RNAi) grown worms. This indicates that part of the decrease in fat storage in the *fat-6;fat-7* double mutants may be due to an increase in the expression of the β -oxidation gene *ech-1*. This may be similar to the low fat phenotype caused by increased energy expenditure in the mouse *SCD1*^{-/-} knockouts. Thus the $\Delta 9$ desaturases are central for energy metabolism in all higher eukaryotes and *C. elegans* is a good simple model for studying the complexities of energy metabolism.

Materials and Methods

Culture of nematodes

Standard conditions. Unless otherwise noted, animals were grown according to standard methods with OP50 *E. coli* as a food source (Wood, 1988).

Dietary Supplementation. A 0.1 M stock solution of fatty acid sodium salts (NuCheck Prep) in water was prepared fresh for each supplementation experiment. The fatty acid stock was added slowly to NGM containing 0.1% tergitol. Plates were poured, covered and allowed to dry in the dark at room temperature overnight. The OP50 strain of *E. coli* was added to each plate and allowed to dry for at least one night (Watts et al., 2003).

RNAi. The *acs-2(RNAi)* and *ech-1(RNAi)* constructs are from the Ahringer RNAi library (Kamath and Ahringer, 2003) and were used as described (Kamath et al., 2001). As a control for RNAi experiments, nematodes were grown on HT115 *E. coli* transformed with an L4440 empty vector plasmid.

Fatty acid and lipid phenotype analysis.

Fatty acid composition. For fatty acid analysis, adult nematodes were washed from plates and allowed to settle. The excess water was removed from the worm pellet and H₂SO₄ was added to generate fatty acid methyl esters (FAMES). After incubation at 80°C for 1 hour the samples were cooled and the FAMES were extracted by adding water and hexane. The hexane containing the FAMES was sampled for determination of fatty acid composition by gas chromatography on an SP-2380 fused silica capillary column (Supelco) using an Agilent 6890 series GC (Watts and Browse, 2002).

Identification of unusual fatty acids. To identify the unusual fatty acids the fatty acid 4,4-Dimethyloxazoline (DMOX) derivatives were prepared from FAMES to stabilize them

for analysis by GC/MS. For the DMOX reaction the FAMES were evaporated using Ar. 300 μ l 9:1 ethoanol:benzene was added and after evaporation 250 μ l of warmed 2-amino-2-methylpropanol (AMP) was added. The reaction was capped and incubated 6 hours at 190°C. To clean the reaction 2.5 ml hexane was added along with 1 ml water. The samples were shaken vigorously and after centrifugation the water was removed. The samples were washed again with water. The hexane layer was then passed through a drying column of glass wool and Na₂SO₄. After evaporation of the solvent with Ar, 300 μ l 9:1 ethanol:benzene was added and then evaporated. The DMOX derivatives were then dissolved in hexane and sampled for determination of the species of fatty acids present. The fatty acids were separated on a 30 m x 0.25 mm AT-WAXms column (Alltech) with an HP6890 series GC system (Hewlett Packard) and the mass spectra were determined on the HP 5973 Mass Selective Detector (Hewlett Packard) (Watts and Browse, 1999).

Nile red analysis. Nile red was added to seeded plates for a final concentration of 0.05 μ g/ml and allowed to dry overnight. Nematode eggs were added to the plates and allowed to develop to adulthood. Adults were visualized by fluorescence microscopy on an Olympus IX70 microscope. Images were captured using a Nikon Coolpix 990 digital camera with identical settings and exposure time for each image.

Lipid composition. For lipid analysis, about 0.5 ml of adult nematodes were collected in a glass tube and frozen. Then 5 ml of cold CHCl₃:CH₃OH (1:1) was added and the samples were mixed. After overnight incubation at -20°C, 2.2 ml Hajra's solution (0.2M H₃PO₄, 1M KCl) was added and the sample was mixed thoroughly. The solution was centrifuged for one minute to separate the phases. The lower phase was sampled to a

new tube and 0.5 ml CHCl₃ was added to the original sample to extract the lower phase again. The combined CHCl₃ extracts were evaporated down to 100 µl using Argon. 200 µl of CHCl₃ was added to wash the sides of the tube and the samples were evaporated down to 100 µl again. CHCl₃ was added to bring the volume to 200 µl. The TLC plates were activated by incubation at 110°C for one hour and fifteen minutes. The samples were loaded onto the TLC plates and the plates were run with the solvent 65 ml chloroform, 43 ml methanol, 3 ml water, 2.5 ml acetic acid until the solvent front is three-fourths of the way up the plate. The plate was dried and a new solvent of 80 ml hexane, 20 ml diethyl ether, 2 ml acetic acid is added. This plate was run until the solvent front at the top of the plate. The marker lanes were visualized using iodine and the corresponding bands for TAG, PE/PI, PS, and PC in the silica gel were scraped into individual tubes. To quantitate 50 µg of 15:0 free fatty acid was added to each tube as an internal standard and fatty acid analysis was performed as described above (Ashrafi et al., 2003).

RT-QPCR analysis

Adult nematodes were harvested and frozen in liquid N₂. RNA was prepared using TRIzol Reagent (Invitrogen). A DNA-FREE RNA kit (Zymo Research) was used for Dnase treatment and purification. After quantification, one µg of RNA was used in a reverse-transcription reaction with SuperScriptIII (Invitrogen) to generate cDNA. Primer sequences for the $\Delta 9$ desaturases and reference genes were designed using PrimerQuest software at www.idtdna.com. Other primer sequences were obtained from Dr. Marc Van Gilst (Van Gilst et al., 2005). The PCR mixture consisted of 0.3 µM primers, cDNA, ROX, and 1x SYBR green mix (Invitrogen Platinum SYBR green qPCR Supermix UDG). The RT-QPCR was run and monitored on a MX3000P (Stratagene). Relative

abundance was determined using the $\Delta\Delta C_t$ method and reference genes such as *tbb-2* and *ubc-2* to control for template levels (Wong and Medrano, 2005).

Growth and development phenotype analysis

Lifespan analysis. Aging experiments were performed on adult nematodes grown at 25°C. Worms were moved to plates containing 5-fluoro-2'-deoxyuridine (Sigma) at the fourth larval stage of development (L4). Live animals were assayed for movement in response to touch every 1-2 days (Apfeld and Kenyon, 1998).

Growth rate analysis. Eggs were isolated using hypochlorite treatment and plated.

Twice a day the number of worms at each life stage was counted.

Fertility analysis. For analysis of total progeny produced per worm, L4 (non-reproductive) worms were isolated and moved to fresh plates. After reaching reproductive viability adults were moved to fresh plates twice daily, as needed. After removal of the adult, the number of eggs on each plate was counted. Two days after removal of the adult, the live progeny were counted. Percent hatching was determined by dividing the number of viable progeny by the number of eggs counted. For analysis of biochemical complementation of fertility, worms were grown from hatching on supplemented plates. They were moved as young adults to supplemented plates of the same type and allowed to lay eggs for two days after which the adult was removed. The number of live progeny was counted on the following day.

References

- Apfeld, J., and Kenyon, C. (1998). Cell nonautonomy of *C. elegans* daf-2 function in the regulation of diapause and life span. *Cell* 95, 199-210.
- Apfeld, J., O'Connor, G., McDonagh, T., DiStefano, P. S., and Curtis, R. (2004). The AMP-activated protein kinase AAK-2 links energy levels and insulin-like signals to lifespan in *C. elegans*. *Genes Dev* 18, 3004-3009.
- Ashrafi, K., Chang, F. Y., Watts, J. L., Fraser, A. G., Kamath, R. S., Ahringer, J., and Ruvkun, G. (2003). Genome-wide RNAi analysis of *Caenorhabditis elegans* fat regulatory genes. *Nature* 421, 268-272.
- Carling, D. (2004). The AMP-activated protein kinase cascade--a unifying system for energy control. *Trends Biochem Sci* 29, 18-24.
- Cohen, P., Yang, G., Yu, X., Soukas, A. A., Wolfish, C. S., Friedman, J. M., and Li, C. (2005). Induction of leptin receptor expression in the liver by leptin and food deprivation. *J Biol Chem* 280, 10034-10039.
- Dobrzyn, P., Dobrzyn, A., Miyazaki, M., Cohen, P., Asilmaz, E., Hardie, D. G., Friedman, J. M., and Ntambi, J. M. (2004). Stearoyl-CoA desaturase 1 deficiency increases fatty acid oxidation by activating AMP-activated protein kinase in liver. *Proc Natl Acad Sci U S A* 101, 6409-6414.
- Farooqi, I. S., Jebb, S. A., Langmack, G., Lawrence, E., Cheetham, C. H., Prentice, A. M., Hughes, I. A., McCamish, M. A., and O'Rahilly, S. (1999). Effects of recombinant leptin therapy in a child with congenital leptin deficiency. *N Engl J Med* 341, 879-884.
- Flier, J. S. (2004). Obesity wars: molecular progress confronts an expanding epidemic. *Cell* 116, 337-350.
- Funk, C. D. (2001). Prostaglandins and leukotrienes: advances in eicosanoid biology. *Science* 294, 1871-1875.
- Hegy, K., Fulop, K., Kovacs, K., Toth, S., and Falus, A. (2004). Leptin-induced signal transduction pathways. *Cell Biol Int* 28, 159-169.
- Heird, W. C., and Lapillonne, A. (2005). The role of essential fatty acids in development. *Annu Rev Nutr* 25, 549-571.
- Kamath, R. S., and Ahringer, J. (2003). Genome-wide RNAi screening in *Caenorhabditis elegans*. *Methods* 30, 313-321.
- Kamath, R. S., Martinez-Campos, M., Zipperlen, P., Fraser, A. G., and Ahringer, J. (2001). Effectiveness of specific RNA-mediated interference through ingested double-stranded RNA in *Caenorhabditis elegans*. *Genome Biol* 2, RESEARCH0002.

Kemp, B. E., Mitchelhill, K. I., Stapleton, D., Michell, B. J., Chen, Z. P., and Witters, L. A. (1999). Dealing with energy demand: the AMP-activated protein kinase. *Trends Biochem Sci* 24, 22-25.

Kopelman, P. G. (2000). Obesity as a medical problem. *Nature* 404, 635-643.

McKay, R. M., McKay, J. P., Avery, L., and Graff, J. M. (2003). *C. elegans*: a model for exploring the genetics of fat storage. *Dev Cell* 4, 131-142.

Miyazaki, M., Kim, H. J., Man, W. C., and Ntambi, J. M. (2001a). Oleoyl-CoA is the major de novo product of stearoyl-CoA desaturase 1 gene isoform and substrate for the biosynthesis of the Harderian gland 1-alkyl-2,3-diacylglycerol. *J Biol Chem* 276, 39455-39461.

Miyazaki, M., Kim, Y. C., Gray-Keller, M. P., Attie, A. D., and Ntambi, J. M. (2000). The biosynthesis of hepatic cholesterol esters and triglycerides is impaired in mice with a disruption of the gene for stearoyl-CoA desaturase 1. *J Biol Chem* 275, 30132-30138.

Miyazaki, M., Kim, Y. C., and Ntambi, J. M. (2001b). A lipogenic diet in mice with a disruption of the stearoyl-CoA desaturase 1 gene reveals a stringent requirement of endogenous monounsaturated fatty acids for triglyceride synthesis. *J Lipid Res* 42, 1018-1024.

Mukhopadhyay, A., Deplancke, B., Walhout, A. J., and Tissenbaum, H. A. (2005). *C. elegans* tubby regulates life span and fat storage by two independent mechanisms. *Cell Metab* 2, 35-42.

Ntambi, J. M., Miyazaki, M., Stoehr, J. P., Lan, H., Kendziorski, C. M., Yandell, B. S., Song, Y., Cohen, P., Friedman, J. M., and Attie, A. D. (2002). Loss of stearoyl-CoA desaturase-1 function protects mice against adiposity. *Proc Natl Acad Sci U S A* 99, 11482-11486.

Pelleymounter, M. A., Cullen, M. J., Baker, M. B., Hecht, R., Winters, D., Boone, T., and Collins, F. (1995). Effects of the obese gene product on body weight regulation in ob/ob mice. *Science* 269, 540-543.

Sasata, R. J., Reed, D. W., Loewen, M. C., and Covello, P. S. (2004). Domain swapping localizes the structural determinants of regioselectivity in membrane-bound fatty acid desaturases of *Caenorhabditis elegans*. *J Biol Chem* 279, 39296-39302.

Smit, E. N., Muskiet, F. A., and Boersma, E. R. (2004). The possible role of essential fatty acids in the pathophysiology of malnutrition: a review. *Prostaglandins Leukot Essent Fatty Acids* 71, 241-250.

Stapleton, D., Woollatt, E., Mitchelhill, K. I., Nicholl, J. K., Fernandez, C. S., Michell, B. J., Witters, L. A., Power, D. A., Sutherland, G. R., and Kemp, B. E. (1997). AMP-activated protein kinase isoenzyme family: subunit structure and chromosomal location. *FEBS Lett* 409, 452-456.

- Sze, J. Y., Victor, M., Loer, C., Shi, Y., and Ruvkun, G. (2000). Food and metabolic signalling defects in a *Caenorhabditis elegans* serotonin-synthesis mutant. *Nature* 403, 560-564.
- Tartaglia, L. A., Dembski, M., Weng, X., Deng, N., Culpepper, J., Devos, R., Richards, G. J., Campfield, L. A., Clark, F. T., Deeds, J., *et al.* (1995). Identification and expression cloning of a leptin receptor, OB-R. *Cell* 83, 1263-1271.
- Van Gilst, M. R., Hadjivassiliou, H., Jolly, A., and Yamamoto, K. R. (2005). Nuclear hormone receptor NHR-49 controls fat consumption and fatty acid composition in *C. elegans*. *PLoS Biol* 3, e53.
- Wallis, J. G., Watts, J. L., and Browse, J. (2002). Polyunsaturated fatty acid synthesis: what will they think of next? *Trends Biochem Sci* 27, 467.
- Watts, J. L., and Browse, J. (1999). Isolation and characterization of a Delta 5-fatty acid desaturase from *Caenorhabditis elegans*. *Arch Biochem Biophys* 362, 175-182.
- Watts, J. L., and Browse, J. (2000). A palmitoyl-CoA-specific delta9 fatty acid desaturase from *Caenorhabditis elegans*. *Biochem Biophys Res Commun* 272, 263-269.
- Watts, J. L., and Browse, J. (2002). Genetic dissection of polyunsaturated fatty acid synthesis in *Caenorhabditis elegans*. *Proc Natl Acad Sci U S A* 99, 5854-5859.
- Watts, J. L., Phillips, E., Griffing, K. R., and Browse, J. (2003). Deficiencies in C20 polyunsaturated fatty acids cause behavioral and developmental defects in *Caenorhabditis elegans* fat-3 mutants. *Genetics* 163, 581-589.
- Wong, M. L., and Medrano, J. F. (2005). Real-time PCR for mRNA quantitation. *Biotechniques* 39, 75-85.
- Wood, W. B. (1988). *The Nematode Caenorhabditis elegans* (Cold Spring Harbor, NY, Cold Spring Harbor Laboratory Press).

	WT	<i>fat-2</i>	<i>fat-3</i>	N2	<i>fat-6;fat-7</i>
Short/branched	11.6	12.9	12.9	14.5	7.8
Cyclopropane	16.5	14.8	21.7	17.5	18.9
18:0	6.8	2.2	3.1	5.7	25.1
18:1 Δ 9	1.7	24.3	3.1	3.7	n.d.
18:1 Δ 11	20.6	36.6	29.6	22.9	20.4
18:1 Δ 13	n.d.	n.d.	n.d.	n.d.	1.8
16:2(Δ 9,12)	n.d.	n.d.	n.d.	n.d.	1.8
18:2	3.8	7.2*	12.7	7.0	n.d.
16:3(Δ 6,9,12)	n.d.	n.d.	n.d.	n.d.	6.3
18:3 ω 6/18:3 ω 3	1.9	n.d.	11	0.7	n.d.
18:3(Δ 8,11,14)	n.d.	n.d.	n.d.	n.d.	5.0
18:4	n.d.	n.d.	n.d.	n.d.	7.1
20:3 ω 6	4.4	0.8*	2.6*	3.4	0.4
20:4 ω 6	1.7	n.d.	n.d.	1.5	0.5
20:4 ω 3	8.7	n.d.	n.d.	4.3	0.3
20:5 ω 3	19.1	1.9	n.d.	13.9	0.4

Table 1. Fatty acid composition of *C. elegans* desaturase mutants. WT, *fat-2*, and *fat-3* data from Watts and Browse, 2002. Short/branched fatty acids are the sum of 14:0, C15iso, 16:0, C17iso, and 16:1 Δ 9. Cyclopropane fatty acids are the sum of 9,10-methylene hexadecanoic acid and 11,12-methylene octadecanoic acid. Asterisk indicate unusual fatty acids in the *fat-2* and *fat-3* mutants. n.d. - not detected (<0.3%).

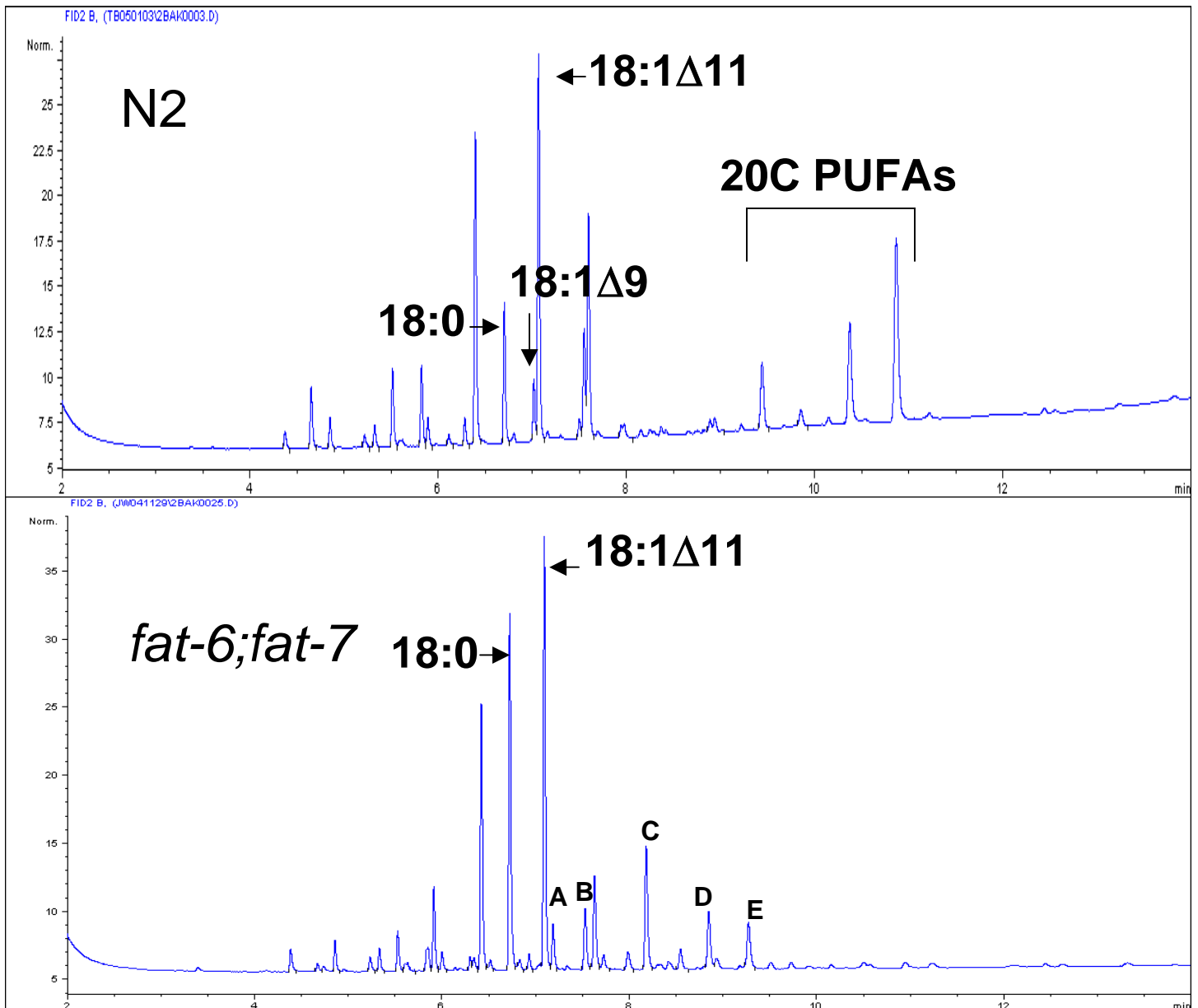


Figure 1. Fatty acid composition of *fat-6;fat-7* double mutants. The *fat-6;fat-7* double mutants lack 18:1Δ9 and the 20-carbon PUFAs. Also they accumulate much higher levels of the SFA 18:0, as well as unusual fatty acids labeled A-E. The identity of these fatty acids is: A-18:1Δ13, B-16:3(Δ6,9,12), C-18:3(Δ8,11,14), D and E are 18:4(Δ5,8,11,14) and 18:4(Δ8,11,14,17).

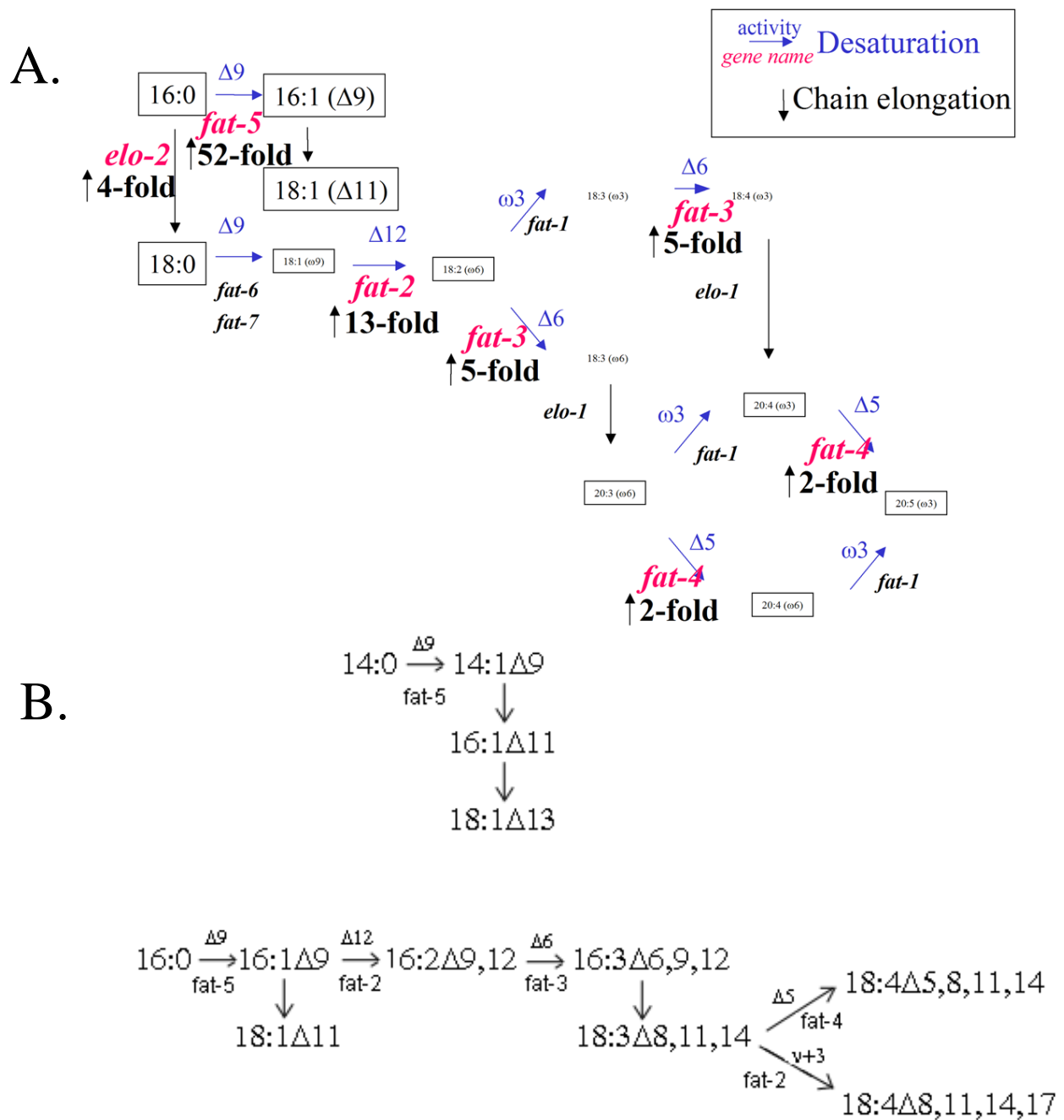


Figure 2. Desaturation pathways in the *fat-6;fat-7* double mutants. **A.** The canonical pathway of fatty acid desaturation in *C. elegans* (Watts, 2002) with the fatty acids not produced in the *fat-6;fat-7* double mutants reduced in size. The fatty acid desaturase genes upregulated in *fat-6;fat-7* double mutants are larger and show the fold increase below the gene name. **B.** Proposed pathways for generation of the unusual fatty acids 16:2(Δ 9,12), 16:3(Δ 6,9,12), 18:1 Δ 13, 18:3(Δ 8,11,14), 18:4(Δ 5,8,11,14), and 18:4(Δ 8,11,14,17) in the *fat-6;fat-7* double mutants.

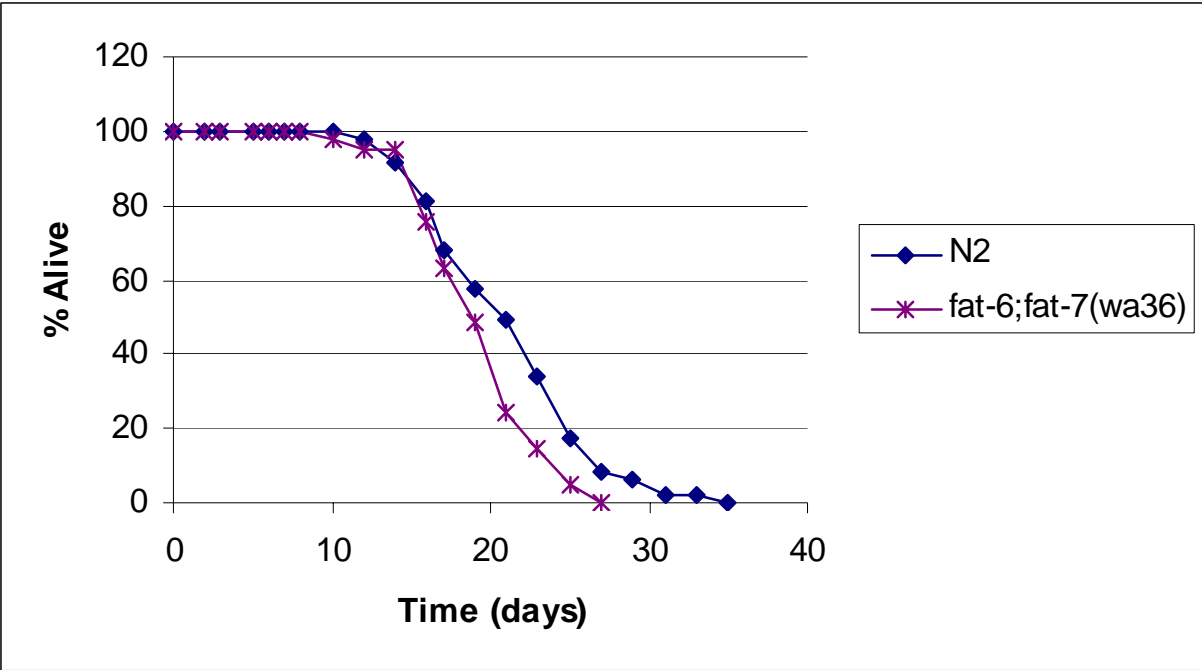
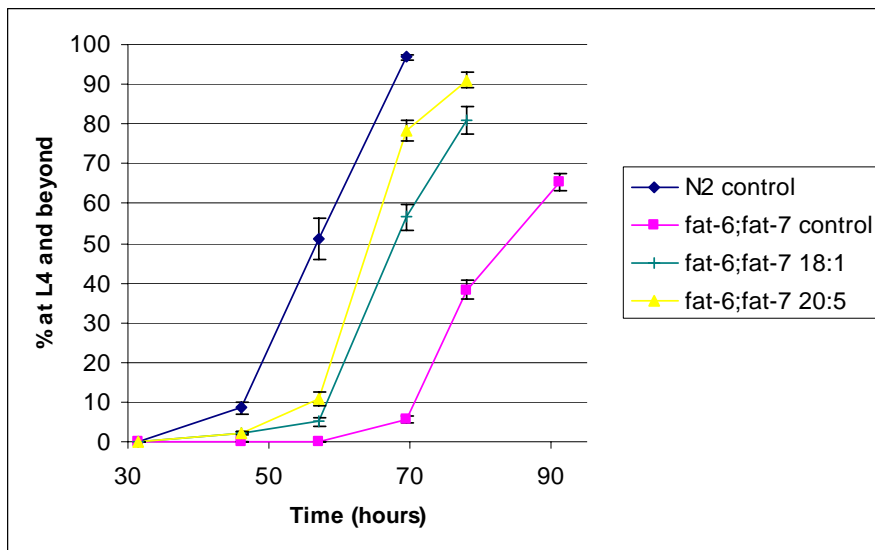


Figure 3. Aging of adult N2 wild-type, and *fat-6;fat-7* double mutant populations at 20°C. Data reported as mean lifespan in days +/- standard error (total number of animals scored). N2: 19.6+/-0.7(47), *fat-6;fat-7*: 17.7+/-0.6(41).

A.



B.

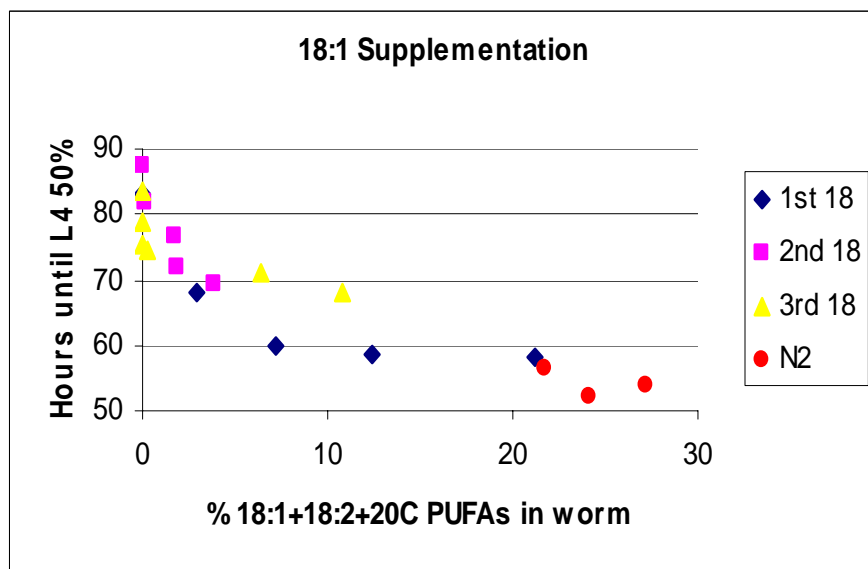


Figure 4. Growth rates in *fat-6;fat-7* double mutants. **A.** Time in hours for animals to reach the L4 stage. N2 wild-type are compared to *fat-6;fat-7* double mutant grown on control, 18:1 Δ 9, or 20:5 ω 3. The time it takes 50% of each population to reach L4 is 57 hours for N2, 83 hours for *fat-6;fat-7*, 64 hours for *fat-6;fat-7* supplemented with 20:5 ω 3, and 68 hours for *fat-6;fat-7* supplemented with 18:1 Δ 9. Error bars represent the standard error. **B.** Dose response curve for three experiments with 18:1 Δ 9 supplementation. The y-axis is the hours for 50% of the population to reach L4. The x-axis is the sum of the % 18:1 Δ 9, 18:2 ω 6, and 20 carbon PUFAs. N2 wild-type are the red circles and the other points are *fat-6;fat-7* from three supplementation experiments.

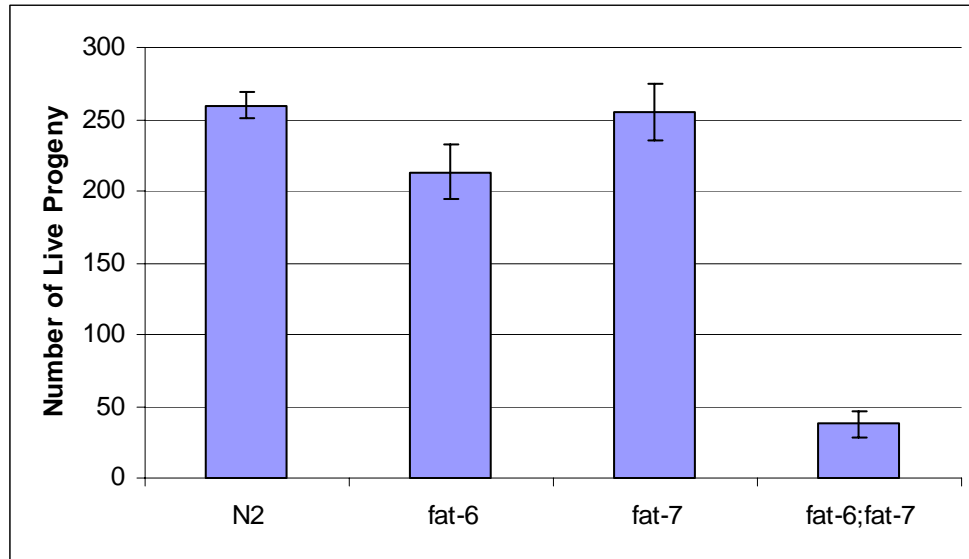
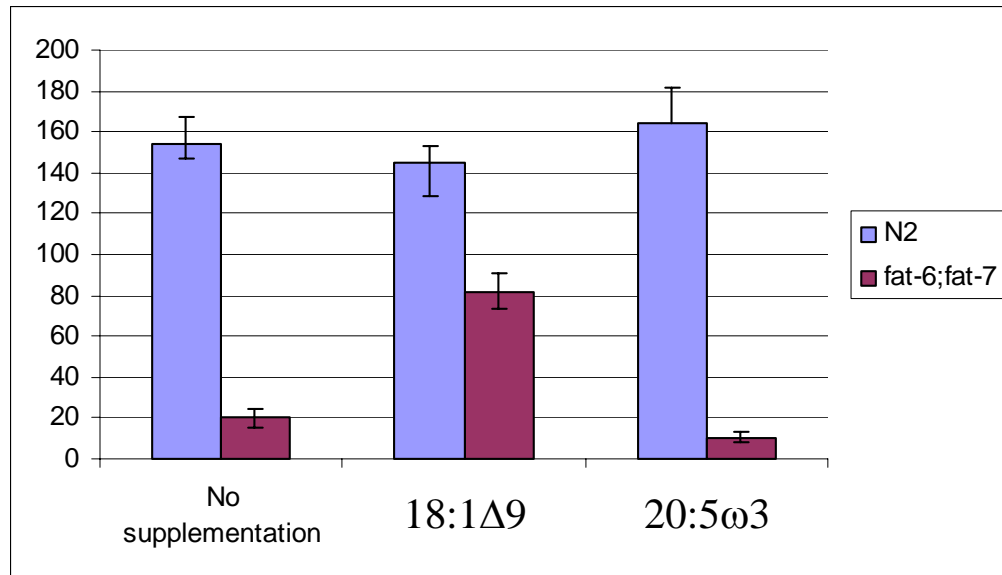
A.**B.**

Figure 5. Fertility in *fat-6;fat-7* double mutants. **A.** Average number of progeny produced per adult for N2, *fat-6*, *fat-7* and *fat-6;fat-7* lines. **B.** Average progeny produced by a single adult over two days for N2 and *fat-6;fat-7* double mutants grown with control, 18:1Δ9 or 20:5ω3 supplementation. All error bars represent standard errors.

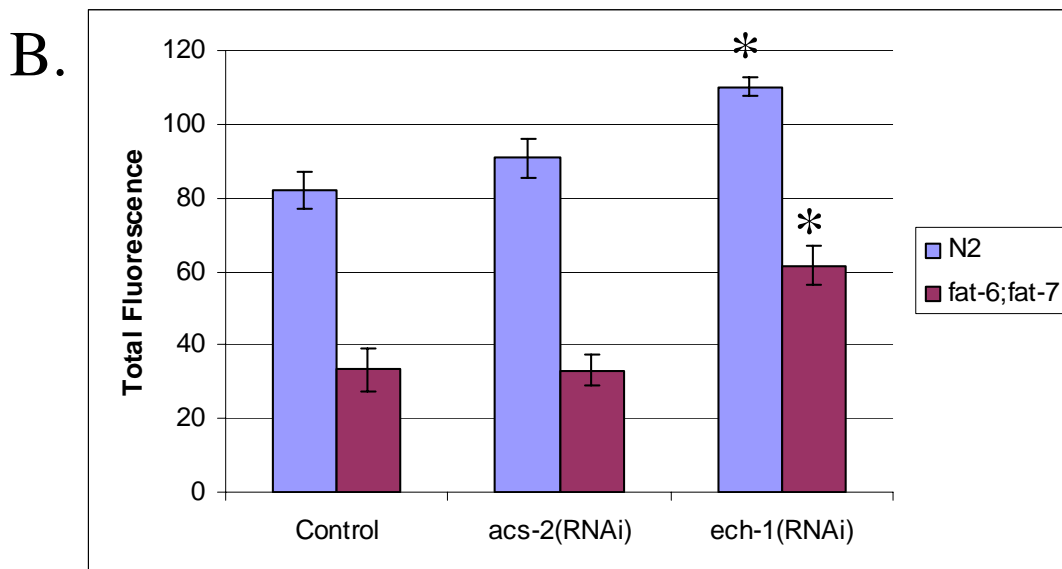
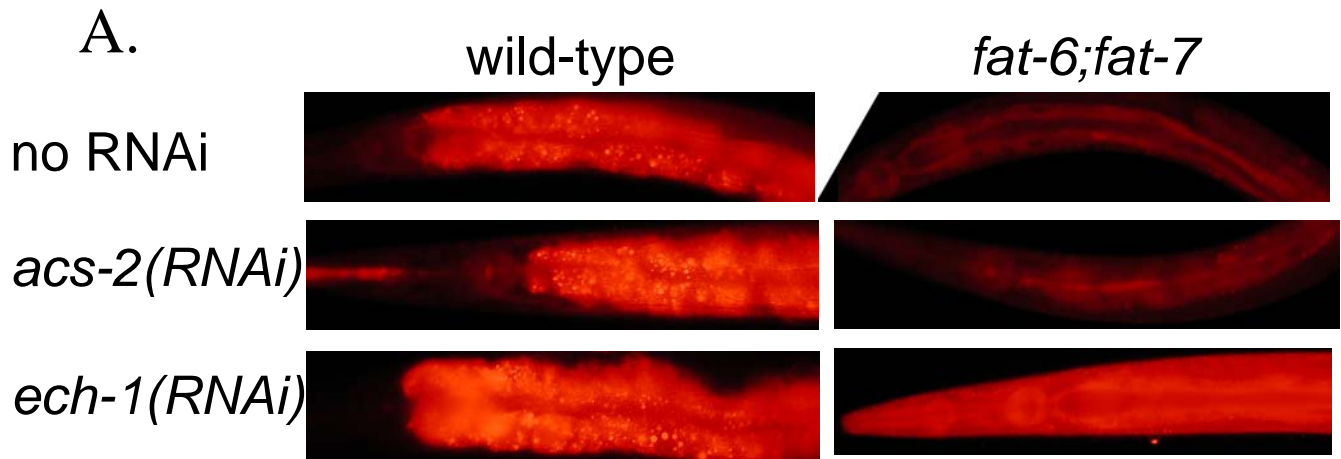


Figure 6. Fat storage by Nile red staining in *fat-6;fat-7* double mutants. **A.** Typical Nile red pictures showing the intestine of N2 wild-type grown on control, *acs-2(RNAi)*, or *ech-1(RNAi)* compared with *fat-6;fat-7* double mutants grown on control, *acs-2(RNAi)*, or *ech-1(RNAi)*. 40X amplification. **B.** Quantification of the Nile red photographs. 3-4 pictures were analyzed twice for each RNAi condition. Error bars represent standard errors and asterisk indicate a significant difference from growth of that strain on control. (P<0.01)

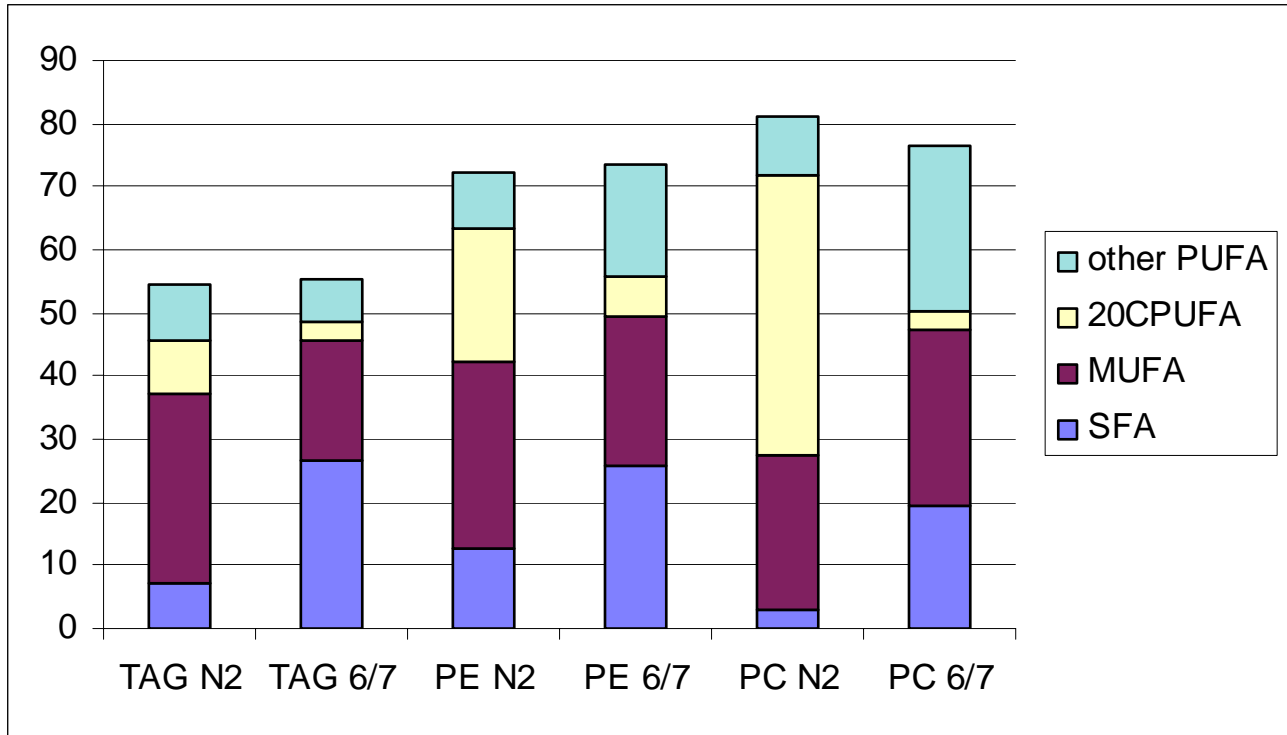


Figure 7. Fatty acid composition of lipid classes in N2 wild-type and *fat-6;fat-7* double mutants. SFA: 14:0, 16:0, and 18:0. MUFA: 16:1 Δ 9, 18:1 Δ 9, 18:1 Δ 11, and 18:1 Δ 13. 20C PUFAs: 20:2, 20:3, 20:4 ω 3, 20:4 ω 6, and 20:5 ω 3. Other PUFAs: 18:2 ω 6, 18:3, 16:3(Δ 6,9,12), 18:3(Δ 8,11,14), 18:4(Δ 5,8,11,14), and 18:4(Δ 8,11,14,17). Not included are the branched chain and cyclopropyl fatty acids.

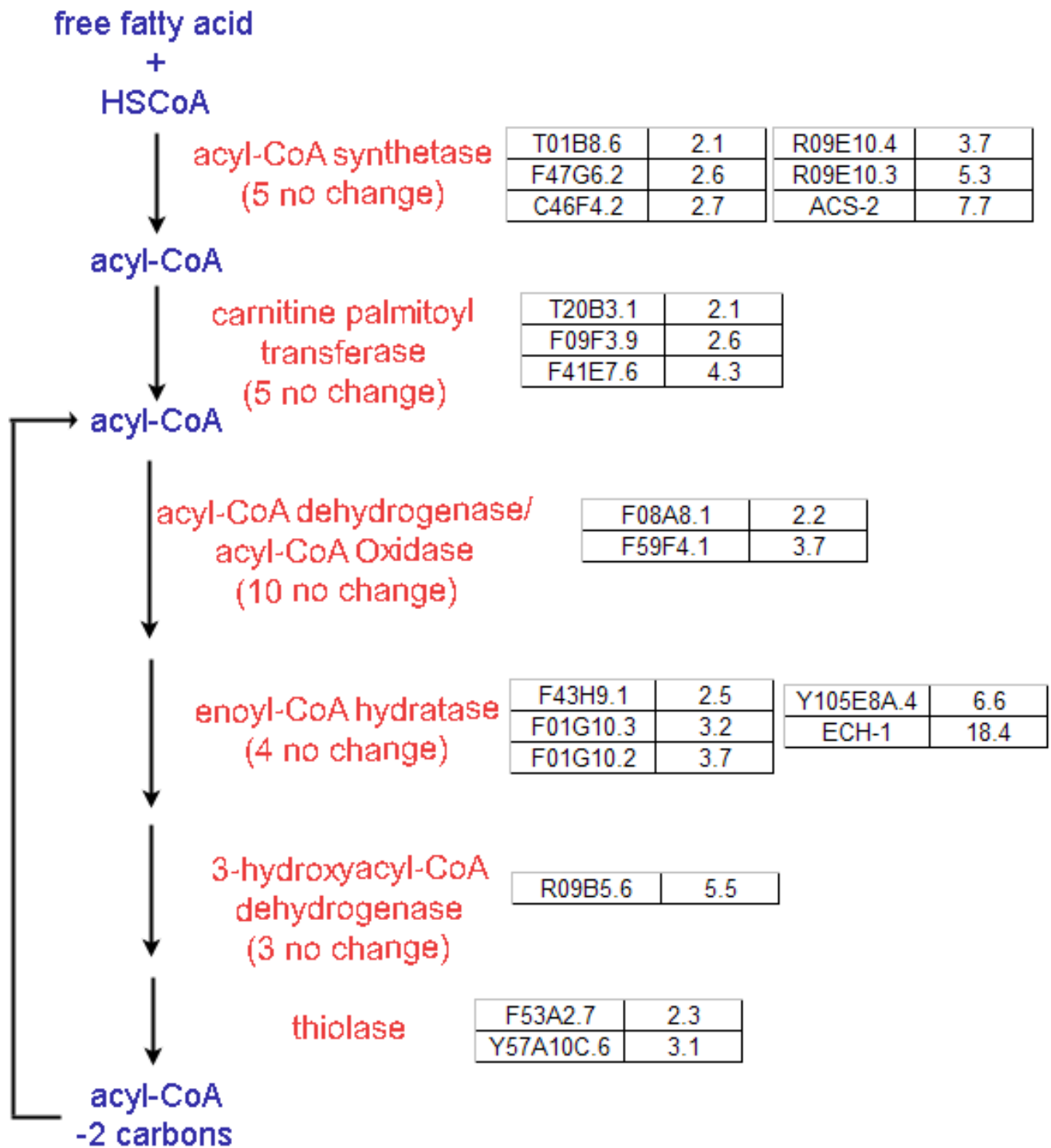


Figure 8. Upregulation of fatty acid β -oxidation genes in *fat-6;fat-7* double mutants. The pathway for β -oxidation and the putative genes involved in *C. elegans* are shown here. Those more than two-fold increased over wild-type are listed along with their increased relative expression over wild-type.

APPENDIX

APPENDIX ONE

CHARACTERIZATION OF THE HIGH 18:0 MUTANTS

Introduction

C. elegans synthesizes a wide range of fatty acids producing 10 major species. This diversity of fatty acids is a result of a number of fatty acid desaturases. In order to identify mutant lines for all steps of the fatty acid desaturation pathway, our lab began a screening program to isolate mutant lines with altered fatty acid profiles. A population of adult worms was mutagenized, and the F1 generation was moved to individual plates and allowed to reproduce. The fatty acid composition of the F2 generation was analyzed. For mutants with an altered fatty acid profile, homozygous lines were identified and retested. Using this method, 15 desaturase mutants as well as other mutations causing a change in fatty acid composition were identified (Watts and Browse, 2002).

Four of the mutants isolated (wa2, wa3, wa13, and wa20) had an increased accumulation of the saturated fatty acid 18:0. For instance, the wa3 mutant had 18% of its fatty acids as 18:0 compared with 6% in wild-type. This high 18:0 was not caused by a mutation in the $\Delta 9$ desaturase genes *fat-5*, *fat-6*, or *fat-7*. Complementation tests were performed and revealed that these mutants were allelic. These mutants were mapped to the end of Chromosome III. Instead of continuing the fine mapping, we turned to RNAi. The goal was to use the Ahringer RNAi library (Kamath and Ahringer, 2003) to identify an RNAi clone that caused an increase in 18:0. We screened the RNAi clones representing 156 ORFs in the mapping window and identified one clone that caused an increase in 18:0 accumulation. This was *nhr-80*; however, sequencing of *nhr-80* in the wa2, wa3, wa13, and wa20 alleles revealed no mutations. The molecular nature of the

high 18:0 mutant remains to be identified but these mutants do have interesting phenotypes. We observed an early death phenotype, sensitivity to cold temperatures, and changes in expression of the $\Delta 9$ desaturase genes with *fat-5* expression severely decreased. These phenotypes provide a foundation for characterization of these mutants with increased 18:0.

Results and Discussion

The high 18:0 mutant wa3 is not an *nhr-80* allele.

One method we used to assess whether the high 18:0 phenotype in wa3 was caused by a mutation in *nhr-80* was to examine the fatty acid profile of wa3 mutants grown on *nhr-80(RNAi)*. If we saw an increase in 18:0 accumulation we would suspect that these effects were caused by separate genes acting in separate pathways. We did not see increased 18:0 in wa2 and wa3 mutants grown on *nhr-80(RNAi)* versus those grown on control bacteria (Figure 1). In wa2 and wa3 grown on control bacteria we saw 18:0 accumulation of 16% and 17% respectively and when those alleles were grown on *nhr-80(RNAi)* the 18:0 accounted for 16% and 15% of the total fatty acids respectively. This could indicate that the high 18:0 is caused by a mutation in *nhr-80* or a mutation in a gene acting in the same pathway as *nhr-80*.

To see if the increased 18:0 in the wa2, wa3, wa13, and wa20 was due to a mutation in *nhr-80* we sequenced *nhr-80* in these alleles. RNA was isolated from all four high 18:0 alleles and RT-PCR using *nhr-80* specific primers amplified *nhr-80* cDNA in all four alleles. This cDNA was sequenced in both directions and was identical to the reported sequence. We then isolated genomic DNA and amplified 4.5 kb of *nhr-80* including 1.6 kb of promoter and 300 bp of 3'UTR. We obtained sequence in one

direction for all of this 4.5 kb region and sequence in two directions for most of the gene. There were no differences from wild-type *nhr-80* in any of the four high 18:0 alleles. Based on this sequencing data we concluded that the high 18:0 in wa2, wa3, wa13, and wa20 is not caused by a mutation in *nhr-80*.

wa3 has a shortened lifespan.

To characterize other phenotypes in the wa3 mutant, we measured the lifespan of adult animals (Figure 2). We found that these worms had an early death phenotype at 25°C. Wild-type worms survived for an average of 11.1±0.4 days as compared to wa3 mutants, which survived for 7.6±0.5 days. This difference is significant with a P value less than 0.01. The *nhr-49* mutant also shows an increased accumulation of 18:0 and a decreased lifespan (Van Gilst et al., 2005). However, it doesn't seem that these two phenotypes are related. The *fat-5;fat-6* (Chapter 3) and *fat-6;fat-7* (Chapter 4) double mutants and the *nhr-80* mutants (Chapter 2) all show an increase in 18:0 but no change in lifespan relative to wild-type. Perhaps the wa3 mutant is related to *nhr-49* in another way.

wa3 is sensitive to cold temperatures.

Because of the change in fatty acid profile of the high 18:0 mutants, we tested the ability of these mutants to survive cold temperatures (Figure 3). Synchronized populations of worms at the first larval stage (L1) were aliquotted onto plates at 20°C, 15°C, and 10°C. When the wild-type worm populations reached adulthood at each temperature, we counted the number of live worms that were not arrested as L1s. The percent survival was then determined relative to the number of live animals at 20°C. While the wild-type populations have similar survival rates at all three temperatures

(100% at 20°C, 92% at 15°C, and 89% at 10°C) the *wa3* mutants show a dramatic decrease in survival at low temperatures (100% at 20°C, 56% at 15°C, and 33% at 10°C). The *wa3* mutants grow more slowly than wild-type and a large number of them die or arrest at L1 when grown at 15°C and 10°C.

This sensitivity to cold temperatures may be at least partially due to the increased 18:0. The ratio of saturated to unsaturated fatty acids in the membrane has a great effect on membrane fluidity. Due to the bend caused by double bonds, unsaturated fatty acids cannot pack as tightly together as saturated fatty acids. This results in unsaturated fatty acids having a lower melting point than saturated fatty acids, which has important consequences for the cell. For example, cells must maintain membrane fluidity for proper membrane function. Wild-type worms have different fatty acid compositions at different temperatures with the general trend being toward decreased saturated and increased unsaturated fatty acids (Tanaka et al., 1996). Perhaps the increased level of 18:0 in the membranes of *wa3* mutants leads to a decreased survival at low temperatures because of failures in membrane function.

***wa3* has dramatically reduced expression of *fat-5*.**

Because of the increased 18:0 saturated fatty acids in *wa3* mutants we wanted to see if there was an effect on $\Delta 9$ desaturase gene expression. These enzymes use saturated fatty acids to generate monounsaturated fatty acids with one double bond at the $\Delta 9$ position (Chapter 2). We isolated RNA from *wa2*, *wa3*, *wa13*, *wa20* and wild-type and used semi-quantitative RT-PCR to analyze $\Delta 9$ desaturase gene expression along with the intestinal actin gene *act-5* as a control for template amount. We saw that the expression of *fat-6* was the same in *wa3* as it was in wild-type controls; however, the expression of

fat-7 was reduced and the expression of *fat-5* was dramatically reduced in *wa3* as compared to the wild-type control (Figure 4).

The saturated fatty acid substrate for FAT-5 is 16:0 not 18:0 (Watts and Browse, 2000) so it is not immediately apparent how a reduction in *fat-5* expression leads to an increase in 18:0 accumulation. Closer examination of the fatty acid profile of *wa3* (Figure 5) shows that the level of 18:1 Δ 11 is decreased in these mutants. 18:1 Δ 11 is the elongation product of 16:1 Δ 9, which is the product of FAT-5 desaturation. So a decrease in *fat-5* expression may be causing the decrease in 18:1 Δ 11 accumulation. This decrease in *fat-5* expression could also lead to an accumulation of 16:0, which is elongated to 18:0 by *elo-2* (Kniazeva et al., 2003). Thus the decrease in *fat-5* expression may indeed account for the increased 18:0 accumulation. These experiments provide a basis for understanding *wa3* but identification of the molecular nature of the *wa3* mutation is necessary for determining the exact function of this gene.

Materials and Methods

Culture of nematodes

Nematodes were grown according to standard methods with OP50 *E. coli* as a food source (Wood, 1988), unless otherwise noted. The RNAi experiments were performed as described (Kamath et al., 2001) using the Ahringer RNAi library (Kamath and Ahringer, 2003) for the RNAi screen for high 18:0 mutants. The *nhr-80(RNAi)* also came from this library. As a control for RNAi experiments, HT115 *E. coli* was transformed with an L4440 empty vector plasmid and grown alongside the RNAi clones.

DNA sequencing

RNA and genomic DNA were used as templates to amplify *nhr-80* from wa2, wa3, wa13, and wa20 populations. cDNA and DNA fragments were gel purified and used as templates for sequencing reactions with the original amplification primers and internal sequencing primers.

Phenotypic analysis

Fatty acid composition. Adult nematodes were prepared for fatty acid composition analysis as described (Watts and Browse, 2002). Determination of fatty acid composition was performed by gas chromatography on an SP-2380 fused silica capillary column (Supelco) using an Agilent 6890 series GC

Lifespan analysis. Aging experiments were performed on adult nematodes grown at 25°C. Worms were moved to plates containing 5-fluoro-2'-deoxyuridine (Sigma) at the fourth larval stage of development (L4). Live animals were assayed for movement in response to touch every 1-2 days (Apfeld and Kenyon, 1998).

Cold temperature growth. Equal numbers of synchronous L1 worms were placed on plates at 20°C, 15°C, and 10°C. The number of live non-arrested worms was counted on each plate when the wild-type population reached adulthood. Numbers are expressed relative to the number of live non-arrested worms counted at 20°C.

Gene Expression

Adult nematodes were harvested in water and frozen using liquid nitrogen. RNA was prepared with the TRIzol Reagent (Invitrogen), then treated with DNase and purified using the DNA-FREE RNA kit (Zymo Research). After quantification, one µg of RNA was used in a reverse-transcription reaction with SuperScript III (Invitrogen) to generate

cDNA. Primer sequences for the $\Delta 9$ desaturase genes and *act-5* were designed to amplify the whole gene. PCRs with wild-type cDNA as a template were stopped after 15, 20, 25, 30, and 35 cycles to determine the logarithmic amplification stage for each gene. That cycle number was used in the semi-quantitative RT-PCRs with cDNA from wa2, wa3, wa13, wa20 and wild-type animals.

References

- Apfeld, J., and Kenyon, C. (1998). Cell nonautonomy of *C. elegans* *daf-2* function in the regulation of diapause and life span. *Cell* 95, 199-210.
- Kamath, R. S., and Ahringer, J. (2003). Genome-wide RNAi screening in *Caenorhabditis elegans*. *Methods* 30, 313-321.
- Kamath, R. S., Martinez-Campos, M., Zipperlen, P., Fraser, A. G., and Ahringer, J. (2001). Effectiveness of specific RNA-mediated interference through ingested double-stranded RNA in *Caenorhabditis elegans*. *Genome Biol* 2, RESEARCH0002.
- Kniazeva, M., Sieber, M., McCauley, S., Zhang, K., Watts, J. L., and Han, M. (2003). Suppression of the ELO-2 FA elongation activity results in alterations of the fatty acid composition and multiple physiological defects, including abnormal ultradian rhythms, in *Caenorhabditis elegans*. *Genetics* 163, 159-169.
- Tanaka, T., Ikita, K., Ashida, T., Motoyama, Y., Yamaguchi, Y., and Satouchi, K. (1996). Effects of growth temperature on the fatty acid composition of the free-living nematode *Caenorhabditis elegans*. *Lipids* 31, 1173-1178.
- Van Gilst, M. R., Hadjivassiliou, H., Jolly, A., and Yamamoto, K. R. (2005). Nuclear hormone receptor NHR-49 controls fat consumption and fatty acid composition in *C. elegans*. *PLoS Biol* 3, e53.
- Watts, J. L., and Browse, J. (2000). A palmitoyl-CoA-specific delta9 fatty acid desaturase from *Caenorhabditis elegans*. *Biochem Biophys Res Commun* 272, 263-269.
- Watts, J. L., and Browse, J. (2002). Genetic dissection of polyunsaturated fatty acid synthesis in *Caenorhabditis elegans*. *Proc Natl Acad Sci U S A* 99, 5854-5859.
- Wood, W. B. (1988). *The Nematode Caenorhabditis elegans* (Cold Spring Harbor, NY, Cold Spring Harbor Laboratory Press).

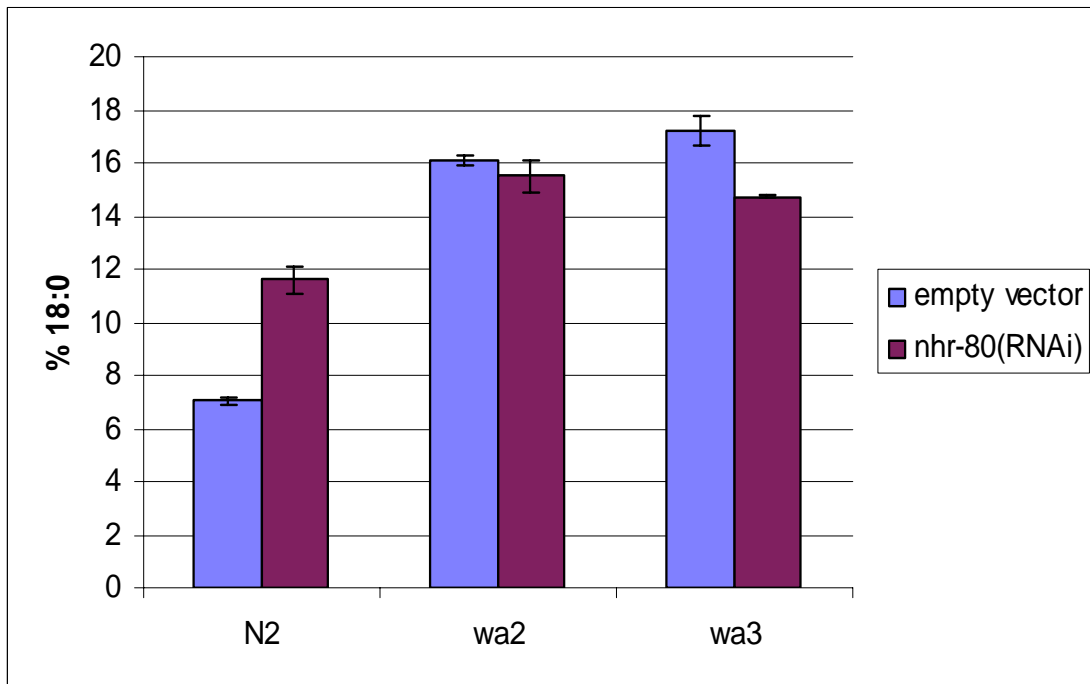


Figure 1. % 18:0 in the high 18:0 mutants grown on *nhr-80(RNAi)*. Relative abundance of 18:0 expressed as a percentage of total fatty acid as determined by GC analysis. Error bars represent the standard error.

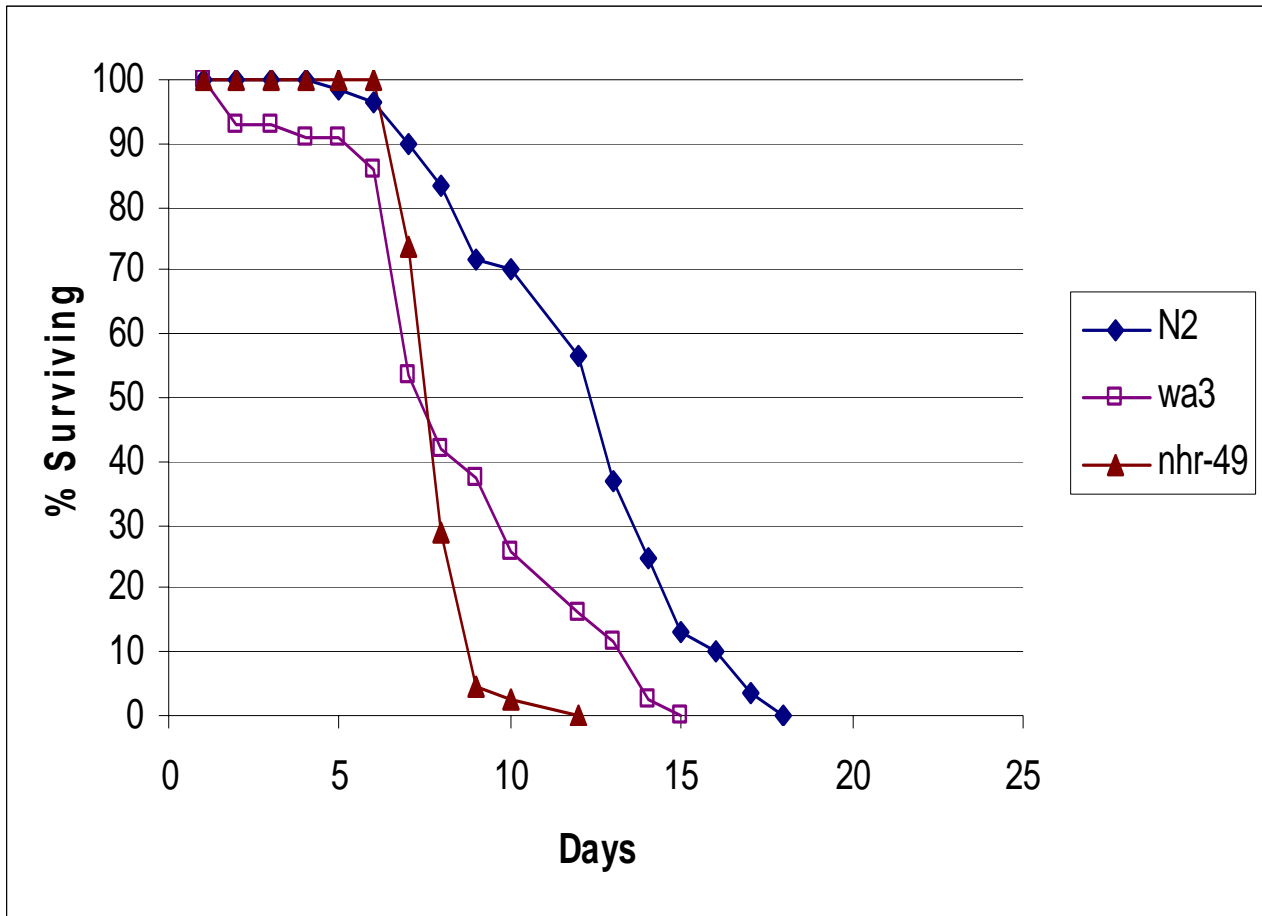


Figure 2. Aging of adult *wa3* mutants. Life span of *wa3*, *nhr-49*, and N2 wild-type. Data reported as mean lifespan in days +/- standard error (total number of animals scored). *wa3*: 7.6+/-0.5 (43), *nhr-49*: 7.1+/-0.1 (42), N2 11.1+/-0.4 (60).

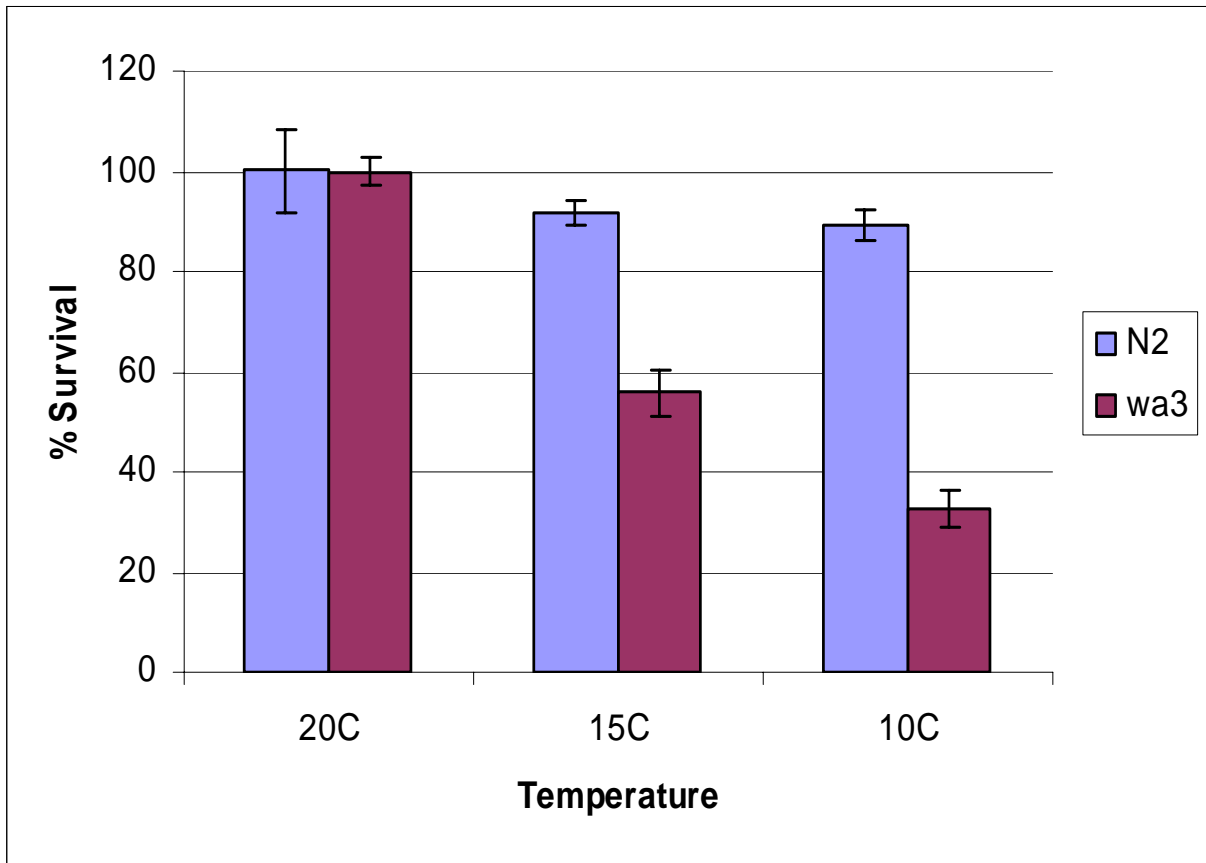


Figure 3. Effects of temperature on wa3. Comparison of survival at 15°C and 10°C relative to survival at 20°C in wa3 and N2 wild-type. Error bars represent the standard error.

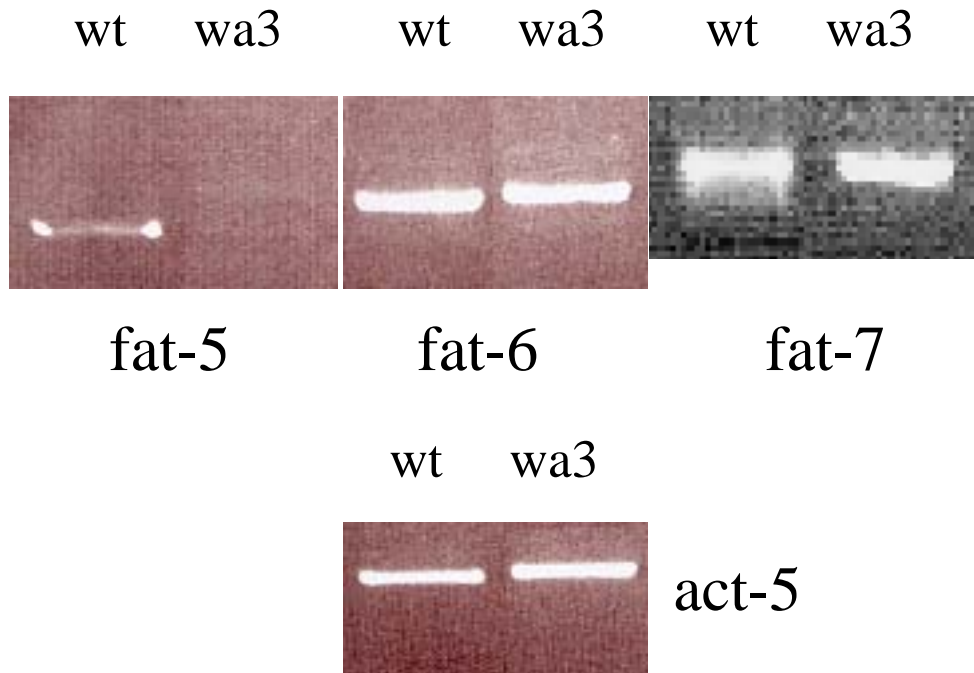


Figure 4. Expression of the $\Delta 9$ desaturases in the high 18:0 mutants. Semi-quantitative RT-PCR of *fat-5*, *fat-6*, and *fat-7* in N2 wild-type and wa3. Expression of *act-5* is used as a template control.

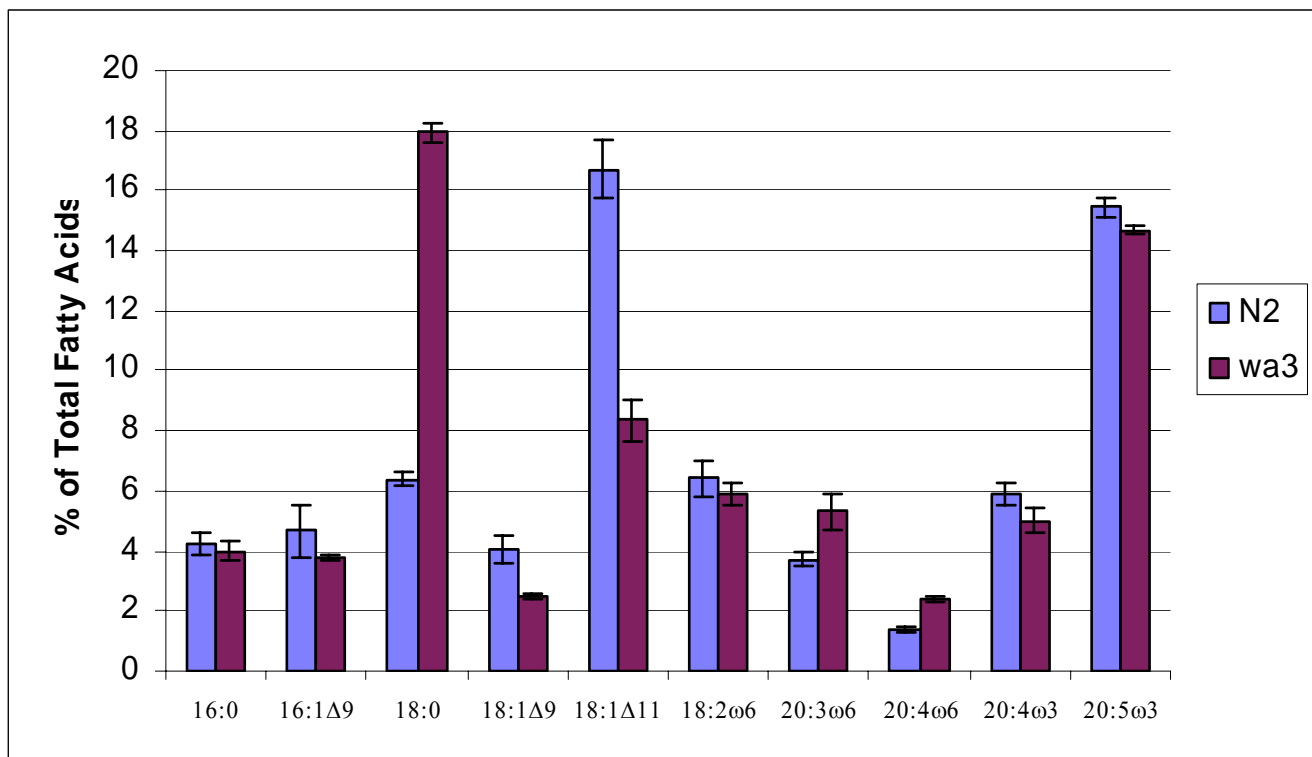


Figure 5. Fatty acid composition of the *wa3* mutants. Relative abundance of selected fatty acid species expressed as percentage of total fatty acid as determined by GC analysis. Error bars represent the standard error.

APPENDIX TWO

THE FAT-7(TM326) ALLELE

Introduction

Reverse genetics is a powerful tool for characterizing gene function. In *C. elegans* the National Bioresource Project was formed in 2002 in part to generate knockout mutants as a service for the research community. Researchers submit requests for target genes and the knockout mutant lines produced are available to the entire community. The knockouts are generated using UV treatment in the presence of the chemical reagent trimethylpsoralen (TMP) (Gengyo-Ando and Mitani, 2000). The TMP intercalates into double stranded DNA and upon UV exposure forms a covalent interstrand crosslink (Greber et al., 2003). This crosslink is then repaired by nucleotide excision and recombinatorial repair which is an error-prone process that often results in deletion mutations (Yandell et al., 1994). A sample experiment in *C. elegans* showed that the probability of a mutation being caused by a detectable deletion was about 24%; however, more complex rearrangements also occurred about 8% of the time (Gengyo-Ando and Mitani, 2000). Deletions are detected by PCR analysis using target gene primers to identify amplicons smaller than wild-type amplicons in a high-throughput manner (Liu et al., 1999). The Consortium isolates homozygous lines and sequences the deletion. If the line is not viable as a homozygote they will cross in a balancer mutation to generate stable balanced heterozygous lines. A balancer is a genomic rearrangement, such as a reciprocal translocation, that reduces or eliminates recombination between mutation-bearing chromosome and a homolog that carries the wild-type allele. For instance the *eTI(III:V)* balancer is a reciprocal exchange of the left half of chromosome

V with the right half of chromosome III (Rosenbluth and Baillie, 1981). The exchanged regions never pair or recombine with their normal homologs and the translocated chromosomes must be inherited as a pair, which allows lethal or sterile mutations to be maintained stably in heterozygotes.

We obtained the *fat-7(tm326)* mutant line from the *C. elegans* Gene Knockout Consortium. This mutation was reported as a 726 bp deletion and 20 bp insertion in the promoter of *fat-7* (Figure 1). This line appeared to be lethal and was outcrossed twice then balanced with *eT1(III:V)* to create the *+eT1III;tm326/eT1V* heterozygote. We attempted to rescue this line by dietary supplementation without success. Further work with this mutation has led us to believe that a genomic rearrangement has occurred and the lethality is not caused solely by the mutation in the *fat-7* promoter.

Results and Discussion

Dietary supplementation of *fat-7(tm326)* does not rescue the lethality.

We used biochemical complementation in an attempt to generate a homozygous *fat-7* mutant line by feeding the worms the fatty acids they lack. This approach has been shown to successfully restore mutant phenotypes back to wild-type (Watts et al., 2003). However, despite repeated attempts with a variety of fatty acids we were not successful in generating a homozygous *fat-7* mutant line. To reduce complications from the balancer, we crossed the *fat-7* mutation to wild-type. Biochemical fatty acid complementation with these worms also did not allow *fat-7(tm326)* homozygotes to survive.

Genomic amplification of the *fat-7(tm326)* suggests severe genomic rearrangement

The *fat-7(tm326)* deletion was identified by PCR; however, in our work with this allele we could only get one upstream primer to amplify the mutant region (Figure 2A and B). We designed primers (TB7 and TB8) to encompass the deletion point and amplify a 1.2 kb region of wild-type *fat-7* and a 538 bp region of *fat-7(tm326)*. The PCRs never produced the shorter mutant amplicon with these primers. We tried additional upstream primers TB34, TB21, and TB43 which should amplify 764 bp, 795 bp, and 2.3 kb regions of *fat-7(tm326)* when used in combination with TB7 but only wild-type sized amplicons were observed. In fact the only upstream primer tested able to amplify the *fat-7(tm326)* deletion was the 3' primer used originally to identify the deletion (TB26). Used in combination with TB7 the products of this PCR are 949 bp for wild-type *fat-7* and 241 bp for *fat-7(tm326)*. Of the five upstream primers tested only one, TB26, was able to amplify the smaller *fat-7(tm326)*. TB26 is only 34 bp from the deletion and primers designed to amplify regions upstream of TB26 were unsuccessful, which indicates a dramatic rearrangement may have occurred in this strain.

Materials and Methods

Dietary supplementation

A 0.1 M stock solution of fatty acid sodium salts (NuCheck Prep) in water was prepared fresh for each supplementation experiment. The fatty acid stock was added slowly to NGM containing 0.1% tergitol. Plates were poured, covered and allowed to dry in the dark at room temperature overnight. The OP50 strain of *E. coli* was added to each plate and allowed to dry for at least one night (Watts et al., 2003). Fatty acid compositions of *E. coli* and *C. elegans* were determined as described (Watts and Browse, 2002) to ensure

fatty acids were taken up by both organisms. Animals were grown for multiple generations on supplemented plates in the attempts to identify a *fat-7(tm326)* homozygote.

Genotyping of *fat-7(tm326)*

Single worm PCR (SWPCR) (Wicks et al., 2001) was used to determine the genotype of worms during biochemical complementation to generate a *fat-7(tm326)* homozygote. A heterozygous population of worms were grown on supplemented plates. They were allowed to reproduce and their progeny were moved to supplemented plates. Once that generation had progeny the adults were picked into worm lysis buffer (50 mM KCl, 10 mM Tris-HCl pH 8.3, 2.5 mM MgCl₂, 0.45% NP-40, 0.45% Tween 20, 0.01% gelatine, freshly added 60 µg/ml proteinase K) for SWPCR analysis. The worms in lysis buffer were frozen at -80 °C for at least 10 minutes then heated to 60°C for 60 minutes to digest the worms. The proteinase K was inactivated by heating to 95 °C for 20 minutes. A PCR mix (2.2 µl 10xPCR buffer, 0.44 µl of 10 µM dNTP, 0.88 µl of each 10 µM primer stock, 1 µl 60% sucrose, 1 µl 0.1% cresol red, 0.22 µl Takara Ex-Taq polymerase, and water to 20 µl) was then added to each reaction and *fat-7* was amplified in a standard PCR reaction using an MJ Research PTC-200 thermal cycler. Amplified products were run on a 0.8% agarose gel and progeny from heterozygous worms were moved to new supplemented plates to continue the next generation.

References

Gengyo-Ando, K., and Mitani, S. (2000). Characterization of mutations induced by ethyl methanesulfonate, UV, and trimethylpsoralen in the nematode *Caenorhabditis elegans*. *Biochem Biophys Res Commun* 269, 64-69.

Greber, B., Lehrach, H., and Himmelbauer, H. (2003). Characterization of trimethylpsoralen as a mutagen for mouse embryonic stem cells. *Mutat Res* 525, 67-76.

Liu, L. X., Spoerke, J. M., Mulligan, E. L., Chen, J., Reardon, B., Westlund, B., Sun, L., Abel, K., Armstrong, B., Hardiman, G., *et al.* (1999). High-throughput isolation of *Caenorhabditis elegans* deletion mutants. *Genome Res* 9, 859-867.

Rosenbluth, R. E., and Baillie, D. L. (1981). The genetic analysis of a reciprocal translocation, eT1(III; V), in *Caenorhabditis elegans*. *Genetics* 99, 415-428.

Watts, J. L., and Browse, J. (2002). Genetic dissection of polyunsaturated fatty acid synthesis in *Caenorhabditis elegans*. *Proc Natl Acad Sci U S A* 99, 5854-5859.

Watts, J. L., Phillips, E., Griffing, K. R., and Browse, J. (2003). Deficiencies in C20 polyunsaturated fatty acids cause behavioral and developmental defects in *Caenorhabditis elegans* fat-3 mutants. *Genetics* 163, 581-589.

Wicks, S. R., Yeh, R. T., Gish, W. R., Waterston, R. H., and Plasterk, R. H. (2001). Rapid gene mapping in *Caenorhabditis elegans* using a high density polymorphism map. *Nat Genet* 28, 160-164.

Yandell, M. D., Edgar, L. G., and Wood, W. B. (1994). Trimethylpsoralen induces small deletion mutation in *Caenorhabditis elegans*. *Proceedings of the National Academy of Sciences* 91, 1381.

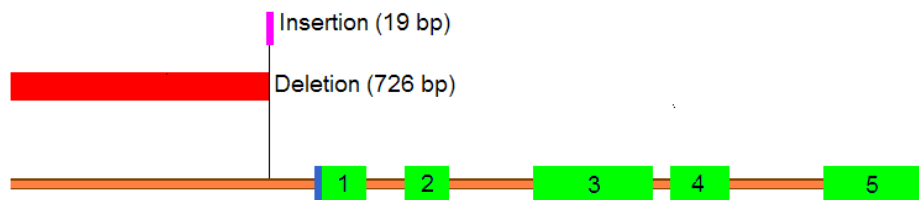


Figure 1. Model of *fat-7* showing the tm326 deletion and insertion. Exons are in green, the 5'UTR is in blue, the deletion is in red, and the insertion is in pink.

A.



Lane #	Upstream Primer	Downstream Primer	Expected wild-type product size	Expected <i>fat-7(tm326)</i> product size
1	TB26	TB7	949 bp	241 bp
2	TB8	TB7	1246 bp	538 bp
3	TB34	TB7	1472 bp	764 bp
4	TB21	TB7	1503 bp	795 bp
5	TB43	TB7	2997 bp	2289 bp
6	TB26	TB22	1222 bp	514 bp

B.

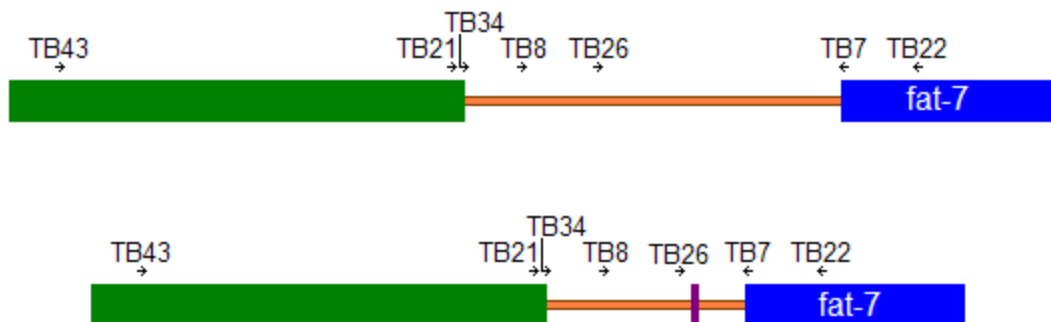


Figure 2. PCR results from *fat-7(tm326)*. **A.** Gel showing the PCR products from six reactions as described in the table. **B.** Diagram showing positions of the primers used. The coding region is in blue, the promoter is in brown, the insertion is in purple, and the nearest gene is in green.

APPENDIX THREE

FAT-7 RNA INHIBITION

Introduction

RNAi has become one of the most powerful and widely used techniques in molecular biology. This silencing system is found in almost all eukaryotes including plants and mammals and is thought to act as an antiviral defense mechanism. Much can be discovered about gene function by studying what happens to an organism when that gene function is eliminated. RNAi offers a rapid and easy way to knockdown expression of genes. Double stranded RNA (dsRNA) enters the cell and is cleaved into small interfering RNAs (siRNAs) by an enzyme called Dicer. The siRNA products are 21-23 nucleotides in length and are incorporated into the RNAi-induced silencing complex (RISC), which is a large multisubunit protein complex. The RISC facilitates the specific interaction between the siRNA and the complementary mRNA. At this point two processes can occur. The interaction between the siRNA and mRNA can lead to immediate cleavage by Dicer. The mRNA is digested and the siRNA-RISC is released to bind more target mRNAs. Alternatively, in the siRNA-mRNA interaction the siRNA can act as a primer for elongation by an RNA-dependent RNA polymerase (RdRP). This creates a new dsRNA molecule, which is then a target for degradation by Dicer creating more siRNAs. This phenomenon is called transitive RNAi and can lead to degradation of closely related genes in the same family as the target gene (Dillin, 2003).

Because of the complications with the *fat-7(tm326)* allele (Appendix 2) we needed a new method to study the effect of *fat-7* loss of function. We decided to use RNAi but soon realized that the RNAi designed to knockdown *fat-7* expression was in

fact knocking down expression of both *fat-6* and *fat-7*. The *fat-7(RNAi)* had a dramatic effect on fatty acid composition and caused lethality in developing animals. This effect could be rescued by specific dietary supplementation revealing a role for specific fatty acids in survival.

Results and Discussion

***fat-7(RNAi)* decreases *fat-6* expression and possibly *fat-5*.**

Using RNAi constructs to deplete *fat-7* in developing larvae we found that worms became thin, slow growing, and unable to produce viable progeny. To test the effectiveness of our RNAi construct we looked at *fat-7::GFP* expression in worms grown on *fat-7(RNAi)* bacteria. After three days of growth on *fat-7(RNAi)* bacteria we see almost no GFP expression in adult *fat-7::GFP* containing nematodes (Figure 1A and B). We also see almost no GFP expression in adult *fat-6::GFP* containing nematodes after three days of growth on *fat-7(RNAi)* (Figure 1C and D). These genes have 86% identity at the nucleotide level so it is believable that RNAi targeted to *fat-7* would also affect *fat-6* expression. Indeed these genes have many 100% identical regions of 20 nucleotides and longer (Figure 2). While we don't have direct evidence that the RNAi is also decreasing expression of *fat-5*, it is likely. The *fat-7(RNAi)* phenotype is stronger than the *fat-6;fat-7* double mutant phenotype (Chapter 4). Also *fat-5* has 61% identity with *fat-7* including several regions of at least 20 nucleotides with only one mismatch (Figure 2). Thus transitive RNAi is likely decreasing expression of all three $\Delta 9$ desaturases.

The fatty acid profile of animals grown on *fat-7(RNAi)* is severely altered from wild-type (Figure 3). The production of 18:1 $\Delta 9$ is almost completely eliminated as is production of the PUFAs that are synthesized from 18:1 $\Delta 9$. For instance the last PUFA

in the desaturation pathway, 20:5 ω 3, is 14% of the total fatty acids in wild-type worms but only 2% in *fat-7(RNAi)* grown worms. The *fat-7(RNAi)* grown animals also display severe growth phenotypes. They are thin and pale in color indicating reduced fat storage. They grow more slowly than wild-type, taking longer to go through the four developmental larval stages. The adults produce far less progeny and the progeny that are produced arrest developmentally before reaching adulthood.

***fat-7(RNAi)* can be rescued by specific dietary fatty acid supplementation.**

We have examined the ability of various dietary monounsaturated fatty acids (MUFAs) and polyunsaturated fatty acids (PUFAs) to rescue *fat-7(RNAi)* and found that 18:1 Δ 9 and 18:2 fatty acids, but not 18:3 ω 6, 20:4 ω 6, or 20:5 ω 3 rescue *fat-7(RNAi)* effects such as fertility (Figure 4). Wild-type embryos were placed on plates with 0.1 mM of one of the fatty acids 18:1 Δ 9, 18:2, 18:3 ω 6, 20:4 ω 6, 20:5 ω 3, or tergitol only as a control. These plates had previously been seeded with HT115 *E. coli* transformed with either a *fat-7(RNAi)* construct or an L4440 empty vector plasmid as a control. When the worms reached the fourth larval stage of development (L4) they were individually moved to a new plate of the same supplementation and bacteria type. The worms were allowed to lay eggs for 48 hours and then removed. The number of live progeny was counted 24 hours later. Without supplementation *fat-7(RNAi)* worms have an average of 12 progeny while control worms have an average of 124 progeny. Dietary supplementation of 18:1 Δ 9 or 18:2 ω 6 rescues progeny production in *fat-7(RNAi)* worms to that of wild-type. However, dietary supplementation with 18:3 ω 6, 20:4 ω 6, or 20:5 ω 3 does not rescue progeny production in *fat-7(RNAi)* worms and in fact these worms produced no progeny while control worm progeny production was not affected.

The lethality of the *fat-7* (RNAi) underscores the essential role the $\Delta 9$ desaturases play in *C. elegans*. Mice with mutations in a $\Delta 9$ desaturase gene, SCD1, are severely affected and cannot be rescued by dietary fatty acids (Miyazaki et al., 2001). In contrast the lethality of *fat-7*(RNAi) can be rescued by specific fatty acids, 18:1 $\Delta 9$ and 18:2. The *fat-7*(RNAi) worms also lack normal levels of the fatty acids 18:3 $\omega 6$, 20:4 $\omega 6$, and 20:5 $\omega 3$ but providing these in the diet does not rescue the phenotypes. Other *C. elegans* desaturase mutants such as *fat-2* and *fat-3* which lack normal levels of PUFAs are also rescued by dietary fatty acids; however, these mutants are rescued by supplementation with the PUFAs 18:3 $\omega 6$, 20:4 $\omega 6$, and 20:5 $\omega 3$ (Watts et al., 2003) while the *fat-7*(RNAi) grown *C. elegans* are not. This suggests a specific requirement for 18:1 $\Delta 9$ or 18:2 $\omega 6$ fatty acids in *C. elegans*.

Materials and Methods

Double-stranded RNA-mediated inhibition (RNAi).

Dr. Jennifer Watts cloned *fat-7* amplified from cDNA into the plasmid L4440, which was then used to transform HT115 *E. coli*. These *E. coli* were grown, along with HT115 *E. coli* containing an empty vector control, on plates containing Ampicillin and IPTG (Kamath et al., 2001). Worms grown on RNAi plates for fatty acid analysis were harvested before the *E. coli* lawn was cleared.

Construction of GFP fusions and microinjection.

Fusion PCR was used to create full-length translational *fat-6* and *fat-7* GFP constructs. The promoters and coding sequences of *fat-6* and *fat-7* were amplified from genomic DNA. The upstream regulatory region for *fat-6* was 2.6 kb and for *fat-7* was 3.0 kb. GFP was amplified from the Fire vector pPD95.75 including the entire coding sequence

and a termination sequence. These PCR products were fused together in a final PCR using nested primers (Hobert, 2002). These fusions were microinjected into *lin-15* mutant *C. elegans* along with a rescuing plasmid containing the wild-type *lin-15* gene (Clark et al., 1994; Mello et al., 1991).

Fatty acid supplementation and analysis.

Fatty acid sodium salts, obtained from NuChek Prep, were prepared fresh at 0.1M by dissolving fatty acids in sterile water. The stock solution was added to NGM agar containing 0.1% tergitol to give a final concentration of 0.1mM. Fatty acid containing plates were kept in the dark as much as possible. The fatty acid content of *C. elegans* was determined as described (Watts and Browse, 2002).

References

- Clark, S. G., Lu, X., and Horvitz, H. R. (1994). The *Caenorhabditis elegans* locus *lin-15*, a negative regulator of a tyrosine kinase signaling pathway, encodes two different proteins. *Genetics* *137*, 987-997.
- Dillin, A. (2003). The specifics of small interfering RNA specificity. *Proc Natl Acad Sci U S A* *100*, 6289-6291.
- Hobert, O. (2002). PCR fusion-based approach to create reporter gene constructs for expression analysis in transgenic *C. elegans*. *Biotechniques* *32*, 728-730.
- Kamath, R. S., Martinez-Campos, M., Zipperlen, P., Fraser, A. G., and Ahringer, J. (2001). Effectiveness of specific RNA-mediated interference through ingested double-stranded RNA in *Caenorhabditis elegans*. *Genome Biol* *2*, RESEARCH0002.
- Mello, C. C., Kramer, J. M., Stinchcomb, D., and Ambros, V. (1991). Efficient gene transfer in *C.elegans*: extrachromosomal maintenance and integration of transforming sequences. *Embo J* *10*, 3959-3970.
- Miyazaki, M., Kim, Y. C., and Ntambi, J. M. (2001). A lipogenic diet in mice with a disruption of the stearoyl-CoA desaturase 1 gene reveals a stringent requirement of endogenous monounsaturated fatty acids for triglyceride synthesis. *J Lipid Res* *42*, 1018-1024.
- Watts, J. L., and Browse, J. (2002). Genetic dissection of polyunsaturated fatty acid synthesis in *Caenorhabditis elegans*. *Proc Natl Acad Sci U S A* *99*, 5854-5859.
- Watts, J. L., Phillips, E., Griffing, K. R., and Browse, J. (2003). Deficiencies in C20 polyunsaturated fatty acids cause behavioral and developmental defects in *Caenorhabditis elegans* *fat-3* mutants. *Genetics* *163*, 581-589.

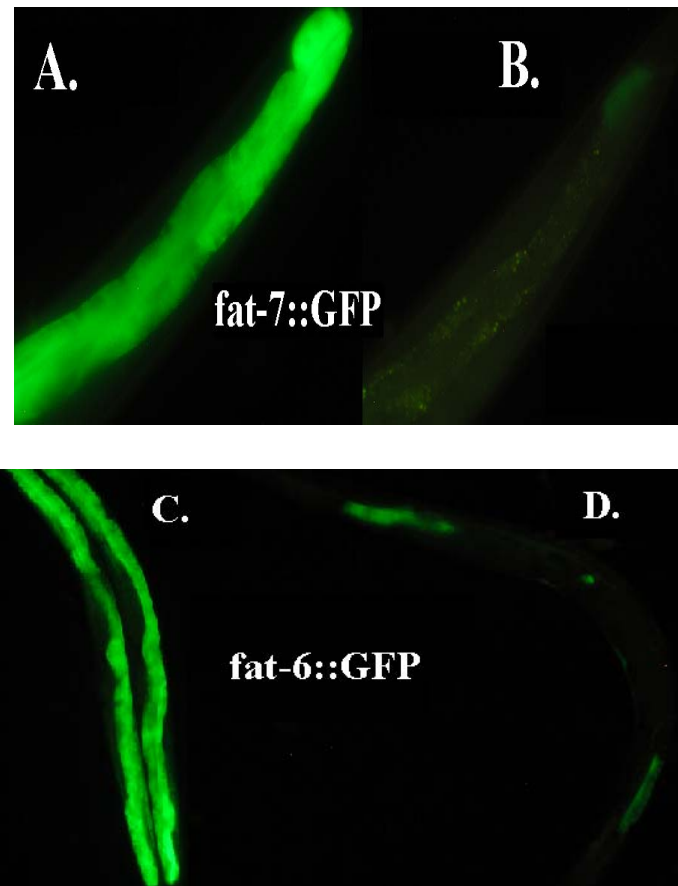


Figure 1. Knock-down of $\Delta 9$ desaturase gene expression by *fat-7(RNAi)*. **A.** *fat-7::GFP* expressing worms grown on empty vector control bacteria. **B.** *fat-7::GFP* expressing worms grown on *fat-7(RNAi)* bacteria. **C.** *fat-6::GFP* expressing worms grown on empty vector control bacteria. **D.** *fat-6::GFP* expressing worms grown on *fat-7(RNAi)*.

		1		50
fat-5 coding	(1)	-----ATGACTCAAAATCAAAGT-AGATGCGATT		
fat-7 coding	(1)	ATGACGGTAAAAACTCGCGCGAGCATTGCCAAGAAGATTGAAAAAGATGG		
fat-6 coding	(1)	ATGACGGTAAAAACTCGTTCAAACATCGCAAAAAGATTGAGAAGGACGG		
Consensus	(1)	ATGACGGTAAAAACTCG C AACATCGCAAA AAGATTGAGAAGGA GG		
		51		100
fat-5 coding	(28)	ATATCTAAA----CAGTTCCTGGCGGCGGACCTGAAACGAGATCCGA	CAAA	
fat-7 coding	(51)	TT---TGGACTCTCAATACCTGTTTCATGGATCCAAATGAAATCCTGCAAG		
fat-6 coding	(51)	CGGCCAGAGACGCAATATCTCGCCGTGGATCCAAATGAAATTATTCAAC		
Consensus	(51)	T CTAGA C CAATACCTGGCCGTGGATCCAAATGAAATCCT CAA		
		101		150
fat-5 coding	(74)	TGCAGGAAGAGAGCAAGAAGCAGGTGATCAAAATGGAAATTGTCTGGAAG		
fat-7 coding	(98)	TCCAAGAGGAGAGCAAAAAAATCCATACAAAATGGAAATAGTGTGGCGT		
fat-6 coding	(101)	TTCAAGAGGAGAGCAAGAAGATCCATATAAAATGGAAATTGTGTGGCGT		
Consensus	(101)	T CAAGAGGAGAGCAAGAAGAT CCATACAAAATGGAAATTGTGTGGCGT		
		151		200
fat-5 coding	(124)	AATGTCGCTTTATTTGTGGCTCTACACATTGGAGCCCTGGTCGGACTATA		
fat-7 coding	(148)	AACGTGGCTCTCTTTGCTGCTCTGCACGTCGCCGCAGCCATTGGACTTTA		
fat-6 coding	(151)	AACGTGGCTCTCTTTGCTGCTCTTCACTTCGCTGCAGCCATCGGACTCTA		
Consensus	(151)	AACGTGGCTCTCTTTGCTGCTCT CAC TCGC GCAGCCATCGGACT TA		
		201		250
fat-5 coding	(174)	TCAGCTTGTGTTCCAGGCCAAGTGGGCTACAGTTGGATGGGTATTCTTCC		
fat-7 coding	(198)	CGAGCTTGTCTTCCATGCTAAATGGCAAACGGCCGTCTTCTCATTGTCTC		
fat-6 coding	(201)	CCAGCTCATCTTCGAGGCAAAATGGCAAACCGTGAATTTTCACATTCTTCC		
Consensus	(201)	CCAGCTTGTCTTCCAGGC AAATGGCAAAC GT GT TTC CATTCTTCC		
		251		300
fat-5 coding	(224)	TGCACACCCTGGGAAGCATGGGTGTCACCGCGGAGCCCATCGTCTCTTGG		
fat-7 coding	(248)	TCTATGTGTTCTCAGGATTCGGTATCACAGCTGGAGCCCATCGTCTCTGG		
fat-6 coding	(251)	TGTATGTGTTCCGAGGATTTGGAATAACCGCCGGAGCTCATCGTCTCTGG		
Consensus	(251)	TGTATGTGTTCCGAGGATT GGTATCACCGCCGGAGCCCATCGTCTCTGG		
		301		350
fat-5 coding	(274)	GCCCACCGAGCCTACAAAGCCACCCTCTCATGGAGAGTATTCTTGATGCT		
fat-7 coding	(298)	TCTCATAAATCATACAAGGCAACCACACCAATGAGAATCTTTTGTATGCT		
fat-6 coding	(301)	TCCCACAAATCATACAAGCAACAACCTCCAATGAGAATCTTCTTGATGAT		
Consensus	(301)	TCCCACAAATCATACAAGCAACCAC CCAATGAGAATCTTCTTGATGCT		
		351		400
fat-5 coding	(324)	CATCAACTCGATCGCTTTCAAAATGACATTATCGACTGGGCCAGAGATC		
fat-7 coding	(348)	CTTGAACAACATTGCTCTTCAAAACGACATCATTGAATGGGCTCGTGATC		
fat-6 coding	(351)	CTTGAACAATATTGCTCTTCAAAATGACGTCATCGAATGGGCTCGTGATC		
Consensus	(351)	CTTGAACAA ATTGCTCTTCAAAATGACATCATCGAATGGGCTCGTGATC		
		401		450
fat-5 coding	(374)	ACCGGTGCCATCACAAGTGGACGGATACTGATGCTGACCCGCATAGCACC		
fat-7 coding	(398)	ATCGTTGCCATCACAAGTGGACTGATACAGATGCTGATCCACATAACACC		
fat-6 coding	(401)	ATCGTTGCCATCACAAGTGGACTGATACCGATGCTGATCCACATAACACC		
Consensus	(401)	ATCGTTGCCATCACAAGTGGACTGATAC GATGCTGATCCACATAACACC		
		451		500
fat-5 coding	(424)	AACCGCGGAATGTTCTTCGCTCATATGGGATGGTTGTTGGTGAAGAAGCA		
fat-7 coding	(448)	ACCCGTGGATTCTTCTTCACTCAATGGGATGGCTTCTTGTGCGTAAGCA		
fat-6 coding	(451)	ACTCGTGGATTCTTCTTCGCTCATATGGGATGGCTTCTTGTGCGTAAGCA		
Consensus	(451)	ACCCGTGGATTCTTCTTCGCTCATATGGGATGGCTTCTTGTGCGTAAGCA		
		501		550
fat-5 coding	(474)	CGATCAGTTGAAGATTCAAGGAGGAAAGTTGGATTTAAGCGATTGTACG		
fat-7 coding	(498)	TCCACAAGTTAAGGAGCATGGAGGCAAACTCGACCTATCTGATCTATTTA		
fat-6 coding	(501)	TCCACAAGTTAAGGAACAAGGAGCAAGCTTGACATGTCTGATCTTTGA		
Consensus	(501)	TCCACAAGTTAAGGA CA GGAGGCAAGCT GAC TATCTGATCT TT A		
		551		600
fat-5 coding	(524)	AGGATCCGGTGCTGATGTTCCAGAGGAAGAACTACCTCCCCTTGGTCGGA		

fat-7 coding	(548)	GCGATCCAGTTCTTGTATTCCAGAGAAAGCACTATTTCCCACTGGTCATT
fat-6 coding	(551)	GTGACCCAGTTCTCGTCTTCCAGAGAAAACATTACTTCCCACTTGTCCATC
Consensus	(551)	G GATCCAGTTCT GT TTCCAGAGAAAGCACTACTTCCCACTGGTCAT
		601 650
fat-5 coding	(574)	ATCTTCTGCTTCGCCCTGCCACCTTCATTCCAGTCGTCTCTGGGGC
fat-7 coding	(598)	TTGTTTGTTTTCATTCTTCCAACAATTATCCCGTTTATTTCTGGAAGGA
fat-6 coding	(601)	TTGTGCTGCTTCATTCTTCCAACAATTATCCCACTTACTTCTGGAAGGA
Consensus	(601)	TTGTTCTGCTTCATTCTTCCAACAATTATCCCACTTACTTCTGGAAGGA
		651 700
fat-5 coding	(624)	GTCAGCCTTCATCGCCTTCTACACGGCCGCCCTCTCCCGTTACTGCTTCA
fat-7 coding	(648)	GACAGCATTTCATTGCGTTTACGTAGCTGGAACATTCGGTTATTGTTTCA
fat-6 coding	(651)	GACTGCATTTCATTGCTTCTACACAGCTGGAACATTCGGTTATTGCTTCA
Consensus	(651)	GACAGCATTTCATTGCTTCTACACAGCTGGAACATTCGGTTATTGCTTCA
		701 750
fat-5 coding	(674)	CCCTCACGCTACATGGTGCATCAACAGTGTCTCCCACTGGGTCGGATGG
fat-7 coding	(698)	CACTTACGCGCACTGGTGCATCAACAGCGCTGCTCACTATTTGGTTGG
fat-6 coding	(701)	CACTTCATGCTACATGGTGCATCAACAGCGCTGCTCACTATTTGGATGG
Consensus	(701)	CACTTACGCTACATGGTGCATCAACAGCGCTGCTCACTATTTGGATGG
		751 800
fat-5 coding	(724)	CAGCCATACGAT-CATCAAGCCTCATCAGTAGACAATCTATGGACATCTA
fat-7 coding	(748)	AAGCCATACGATACTTCTGTTTCCG-CCGTTGAGAACGTCTTTACCACAG
fat-6 coding	(751)	AAGCCATACGATTCTCAATTACC-CAGTCGAAAACGTCTTACCACAA
Consensus	(751)	AAGCCATACGAT C TCAATT CC CAGT GA AACGTCTT ACCACAA
		801 850
fat-5 coding	(773)	TTGCGGCAGTCGGAGAAGGAGGTCACAACTACCATCACACCTTCCCACAG
fat-7 coding	(797)	TTGTAGCCGTTGGTGAAGGAGGTCACAATTTCCACCACACATTCCCACAA
fat-6 coding	(800)	TTGCTGCCGTCGGAGAGGGAGGTCACAACTTCCATCACACATTCCCACAA
Consensus	(801)	TTGC GCCGTCCGAGAAGGAGGTCACAACTTCCATCACACATTCCCACAA
		851 900
fat-5 coding	(823)	GACTATAGAACTTCCGAGCACGCGGAGTTCCTGAACTGGACCCGAGTATT
fat-7 coding	(847)	GACTACAGAGCATCTGAATAATTCATTGATATACAATTGGACCCGTGTTCT
fat-6 coding	(850)	GACTACAGAACATCTGAATACTCATTGAAATACAATTGGACACGTGCTCT
Consensus	(851)	GACTACAGAACATCTGAATACTCATTGATATACAATTGGACCCGTGT CT
		901 950
fat-5 coding	(873)	GATTGATTTCCGGGCGTCTATTGGAATGGTGTATGATCGGAAAGACTACTC
fat-7 coding	(897)	TATTGATACTGCAGCTGTTCTTGGTCTTGTCTACGATAGAAAAACAATTG
fat-6 coding	(900)	TATTGATACTGCAGCTGCTCTTGGACTTGTCTACGACCGGAAAACCTGCTT
Consensus	(901)	TATTGATACTGCAGCTGCTCTTGGACTTGTCTACGATCGGAAAACACTACT
		951 1000
fat-5 coding	(923)	CGGAAGAGGTAATACAAAACAGTGCAAGAAAGTTCCGGCTGTGAA-ACTGA
fat-7 coding	(947)	CCGATGAGTTTATCAGCCGGCAGGTTGCCAATCACGGAAGTGAAATCA
fat-6 coding	(950)	GTGATGAGATTATCGGCCGGCAGGTATCCAATCATGGATGTGAT-ATTCA
Consensus	(951)	C GATGAG TTATC GCCGGCAGGT CCAATCACGGATGTGAA A TCA
		1001 1031
fat-5 coding	(972)	ACGGGAGAAAATGCTCCACAAAATTGGGATAA
fat-7 coding	(997)	AGAAA--AAAATCGATCATGTAA-----
fat-6 coding	(999)	ACGAG-GAAAATCAATCATGTAA-----
Consensus	(1001)	ACGAG GAAAATC ATCATGTAA

Figure 2. Sequence alignment of *fat-5*, *fat-6*, and *fat-7*. Yellow indicates sequence identity in all three genes. Blue indicates sequence identity in two genes. *fat-5* and *fat-7* are 61% identical. *fat-6* and *fat-7* are 86% identical.

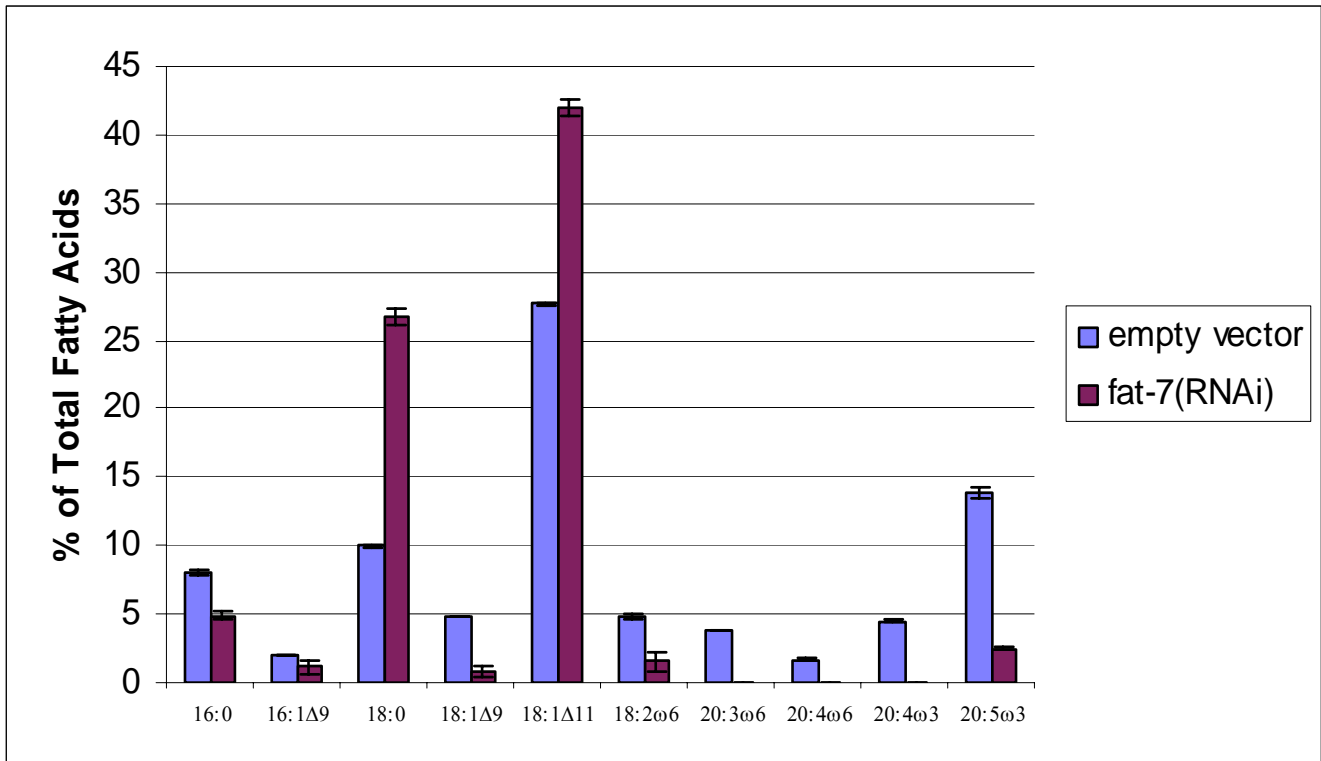


Figure 3. Fatty acid composition of *fat-7(RNAi)* worms. Relative abundance of selected fatty acid species expressed as percentage of total fatty acid as determined by GC analysis. Error bars represent the standard error.

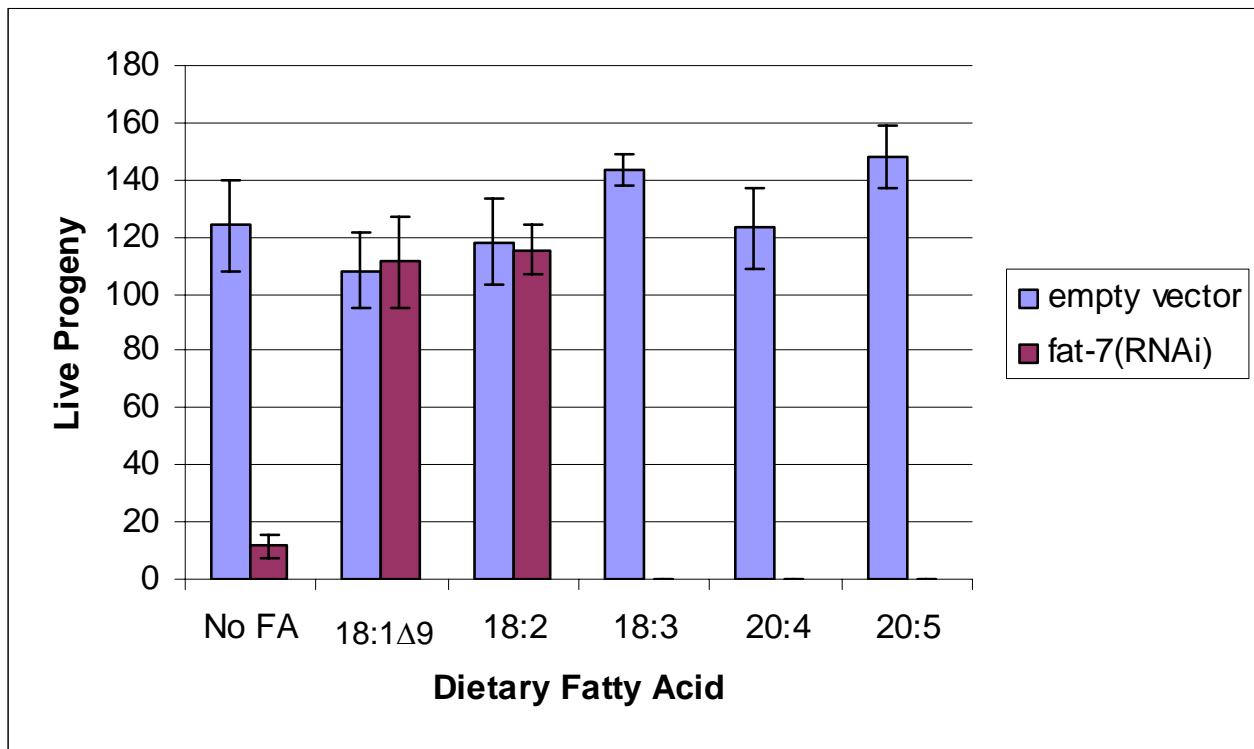


Figure 4. Fertility of *fat-7(RNAi)* worms. Live progeny were counted from worms grown on empty vector and *fat-7(RNAi)* bacteria with a variety of fatty acid species supplemented in their diets. Error bars represent the standard error.